



Electromechanical axis Series 5ES...BS

Series 5ES...BS axes are mechanical linear actuators in which the rotary movement generated by a motor is converted into a linear movement by means of a recirculating ball screw.



- » Multiposition system with transmission of the movement with a recirculating ball screw
- » High load carrying capacity
- » High precision and repeatability
- » IP 40
- » Large range of axis mounting accessories

Series 5E is designed with a special self-supporting square profile with a recirculating ball guide integrated within the actuator, providing exceptional stiffness and resistance to external loads. A stainless steel plate protects against the ingress of contaminating agents from the surrounding environment, especially dust and dirt.

The axis is available in three sizes; 50, 65 and 80. They can be combined in different configurations to create multi-axis systems. Thanks to the wide range of accessories, assembly is simple and intuitive, reducing assembly and commissioning times considerably. The axis equipped with recirculating ball screw is particularly suitable for applications requiring a high repeatability and a high load capacity.

GENERAL DATA

Construction	electromechanical axis with recirculating ball screw
Design	open profile with protection plate
Sizes	50, 65, 80
Strokes	15 ÷ 1000 mm for size 50; 15 ÷ 1500 mm for size 65; 15 ÷ 2000 mm for size 80;
Type of guide	internal, with recirculating ball screw (cage type)
Fixing	by means of slots on the profile and special clamps
Mounting motor	in line and parallel
Operating temperature	-10°C ÷ +50°C
Storage temperature	-20°C ÷ +80°C
Protection class	IP 40
Lubrication	centralized lubrication by means of internal channels
Repeatability	± 0.02 mm
Duty cycle	100%
Use with external sensors	Series CSH magnetic switches in special slots

CODING EXAMPLE

5E	S	050	BS	05P	0200	A	S	1
-----------	----------	------------	-----------	------------	-------------	----------	----------	----------

5E	SERIES
S	PROFILE S = square section
050	SIZE 050 = 50x50 mm 065 = 65x65 mm 080 = 80x80 mm
BS	TRANSMISSION BS = recirculating ball screw
05P	SCREW PITCH 00P = without spindle (only for D version) 05P = 5 mm 10P = 10 mm 16P = 16 mm (only for size 080)
0200	TOTAL STROKE (TS) See table of mechanical characteristics
A	VERSIONS A = standard axis D = support axis (dummy)
S	TYPE OF SLIDER S = standard C = short
1	NUMBER OF SLIDERS 1 = 1 slider

SERIES 5ES...BS ELECTROMECHANICAL AXIS

MATERIALS SERIES 5ES...BS

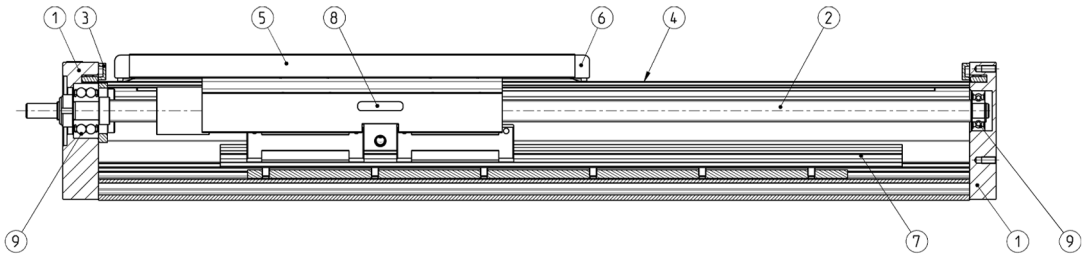

PARTS	MATERIALS
1. End cap	Aluminium alloy
2. Recirculating ball screw	Steel
3. Cover of end cap	Technopolymer
4. Protection plate	Stainless steel
5. Slider	Aluminium alloy
6. Cover of slider	Technopolymer
7. Recirculating ball guide	Steel
8. Magnet	Neodymium
9. Ball bearing	Steel

MECHANICAL CHARACTERISTICS

SERIES 5ES...BS ELECTROMECHANICAL AXIS

MECHANICAL CHARACTERISTICS SIZE 50						
SCREW AND GUIDE		Size 50	Size 50	Size 50	Size 50	Size 50
Version		A	A	D	A	D
Type of slider		S	S	S	C	C
Pitch "P"	mm	5	10	-	5	10
Dynamic load coefficient	N	6600	4400	-	6600	4400
Fx, eq ^(A)	N	900	700	-	900	700
Maximum static load ^(B)	N	1000	700	-	1000	700
Max torque applicable to screw's shaft	Nm	0,88	1,24	-	0,88	1,24
Max linear speed ^(B)	m/s	0,56	1,00	-	0,56	1,00
Max rotational speed ^(B)	rpm	6720	6000	-	6720	6000
Max linear mechanical acceleration (a _{max})	m/s ²	25	25	-	25	25
Fy, eq ^(A)	N	3400	3400	3400	1700	1700
Fz, eq ^(A)	N	3400	3400	3400	1700	1700
Mx, eq ^(A)	Nm	19,4	19,4	19,4	11,2	11,2
My, eq ^(A)	Nm	91,7	91,7	91,7	9,11	9,11
Mz, eq ^(A)	Nm	91,7	91,7	91,7	9,11	9,11
PROFILE						
Moment of surface inertia I _y	mm ⁴	1,89 · 10 ⁵	1,89 · 10 ⁵	1,89 · 10 ⁵	1,89 · 10 ⁵	1,89 · 10 ⁵
Moment of surface inertia I _z	mm ⁴	2,48 · 10 ⁵	2,48 · 10 ⁵	2,48 · 10 ⁵	2,48 · 10 ⁵	2,48 · 10 ⁵
STROKE						
Min Stroke	mm	15	25	15	15	25
Max stroke	mm	1000	1000	1000	1000	1000
Extra stroke	mm	10	10	10	10	10

MECHANICAL CHARACTERISTICS SIZE 65						
SCREW AND GUIDE		Size 65	Size 65	Size 65	Size 65	Size 65
Version		A	A	D	A	D
Type of slider		S	S	S	C	C
Pitch "P"	mm	5	10	-	5	10
Dynamic load coefficient	N	6600	4400	-	6600	4400
Fx, eq ^(A)	N	900	750	-	900	750
Maximum static load ^(B)	N	2000	1100	-	2000	1100
Max torque applicable to screw's shaft	Nm	1,77	1,95	-	1,77	1,95
Max linear speed ^(B)	m/s	0,56	1,00	-	0,56	1,00
Max rotational speed ^(B)	rpm	6720	6000	-	6720	6000
Max linear mechanical acceleration (a _{max})	m/s ²	25	25	-	25	25
Fy, eq ^(A)	N	8300	8300	8300	4150	4150
Fz, eq ^(A)	N	8300	8300	8300	4150	4150
Mx, eq ^(A)	Nm	47,7	47,7	47,7	27,4	27,4
My, eq ^(A)	Nm	282,3	282,3	282,3	30,0	30,0
Mz, eq ^(A)	Nm	282,3	282,3	282,3	30,0	30,0
PROFILE						
Moment of surface inertia I _y	mm ⁴	4,94 · 10 ⁵	4,94 · 10 ⁵	4,94 · 10 ⁵	4,94 · 10 ⁵	4,94 · 10 ⁵
Moment of surface inertia I _z	mm ⁴	6,97 · 10 ⁵	6,97 · 10 ⁵	6,97 · 10 ⁵	6,97 · 10 ⁵	6,97 · 10 ⁵
STROKE						
Min Stroke	mm	15	25	15	15	25
Max stroke	mm	1000	1500	1500	1000	1500
Extra stroke	mm	10	10	10	10	10

MECHANICAL CHARACTERISTICS SIZE 80								
SCREW AND GUIDE		Size 80	Size 80	Size 80	Size 80	Size 80	Size 80	Size 80
Version		A	A	A	D	A	A	D
Type of slider		S	S	S	S	C	C	C
Pitch "P"	mm	5	10	16	-	5	10	16
Dynamic load coefficient	N	12000	8500	9150	-	12000	8500	9150
F _{x, eq} ^(A)	N	1600	1450	1800	-	1600	1450	1800
Maximum static load ^(B)	N	4300	3400	4300	-	4300	3400	4300
Max torque applicable to screw's shaft	Nm	3,8	6	12,1	-	3,8	6	12,1
Max linear speed ^(B)	m/s	0,42	1,00	1,30	-	0,42	1,00	1,30
Max rotational speed ^(B)	rpm	5040	6000	4875	-	5040	6000	4875
Max linear mechanical acceleration (a _{max})	m/s ²	25	25	25	-	25	25	25
F _{y, eq} ^(A)	N	13000	13000	13000	13000	6500	6500	6500
F _{z, eq} ^(A)	N	13000	13000	13000	13000	6500	6500	6500
M _{x, eq} ^(A)	Nm	106	106	106	106	61,3	61,3	61,3
M _{y, eq} ^(A)	Nm	626	626	626	626	56,7	56,7	56,7
M _{z, eq} ^(A)	Nm	626	626	626	626	56,7	56,7	56,7
PROFILE								
Moment of surface inertia I _y	mm ⁴	1,23 · 10 ⁶	1,23 · 10 ⁶	1,23 · 10 ⁶	1,23 · 10 ⁶	1,23 · 10 ⁶	1,23 · 10 ⁶	1,23 · 10 ⁶
Moment of surface inertia I _z	mm ⁴	1,68 · 10 ⁶	1,68 · 10 ⁶	1,68 · 10 ⁶	1,68 · 10 ⁶	1,68 · 10 ⁶	1,68 · 10 ⁶	1,68 · 10 ⁶
STROKE								
Min Stroke	mm	15	25	40	15	15	25	40
Max stroke	mm	1500	2000	2000	2000	1500	2000	2000
Extra stroke	mm	10	10	10	10	10	10	10

^(A) Value refers to a covered distance of 2000 Km with fully supported system.

^(B) Variable value according to the stroke, see graphs below.

HOW TO CALCULATE THE LIFE OF THE GUIDE

L_{eq} = Life of the axis [km]

f_l = load coefficient

f_w = safety coefficient according to the working conditions

The loads acting on the actuator (F_y, F_z, M_x, M_y and M_z) that appear in the fl calculation are the average ones on the cycle. These are calculated by averaging the loads of each single phase as indicated in the equation of P.

l_s = stroke

s₁ = acc. phase; s₂ = constant speed phase; s₃ = deceleration phase

P = M_x / M_y / M_z / F_y / F_z

$$f_l = \frac{|F_y|}{F_{y, eq}} + \frac{|F_z|}{F_{z, eq}} + \frac{|M_x|}{M_{x, eq}} + \frac{|M_y|}{M_{y, eq}} + \frac{|M_z|}{M_{z, eq}}$$

$$L_{eq} = \left(\frac{1}{f_l \cdot f_w} \right)^3 \cdot 2000$$

$$P = \sqrt[3]{\frac{1}{l_s} \cdot \sum_{i=1}^n (P_i^3 \cdot s_i)}$$

$$P = \sqrt[3]{\frac{1}{l_s} \cdot (P_1^3 \cdot s_1 + P_2^3 \cdot s_2 + P_3^3 \cdot s_3)}$$

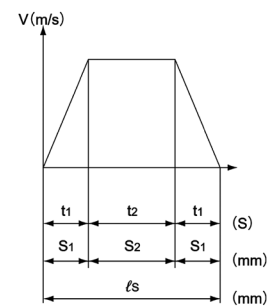

EQUIVALENT LOAD

- Fy = Force acting along the Y-axis [N]
- Fz = Force acting along the Z-axis [N]
- h = fixed distance for 5E axis [mm]
- Mx = Moment along X-axis [Nm]
- My = Moment along Y-axis [Nm]
- Mz = Moment along Z-axis Z [Nm]

Here you can find the "h" values, valid for version A:

- h = 45.5 mm (5ES050)
- h = 56.0 mm (5ES065)
- h = 69.5 mm (5ES080)

Here you can find the "A" value, valid for version H:

- "A" = 56.0 mm "B" 32.9 mm (5ES050)
- "A" = 57.0 mm "B" 45.0 mm (5ES065)
- "A" = 71.6 mm "B" 51.6 mm (5ES080)

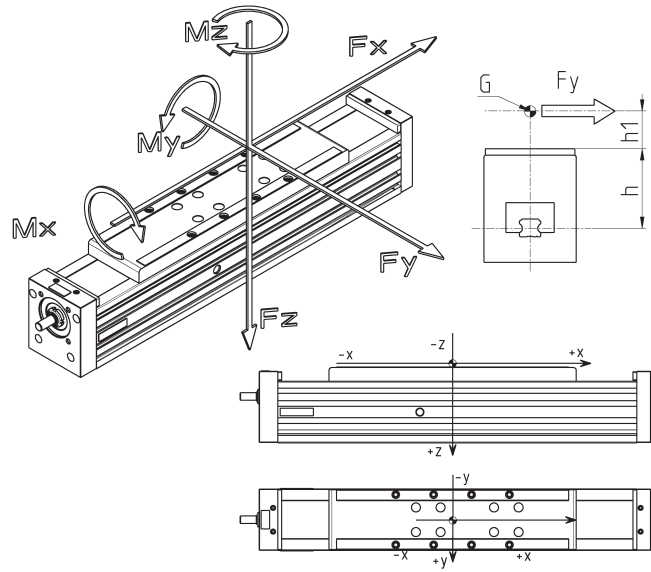

GRAPH OF THE SERVICE LIFE OF THE GUIDE

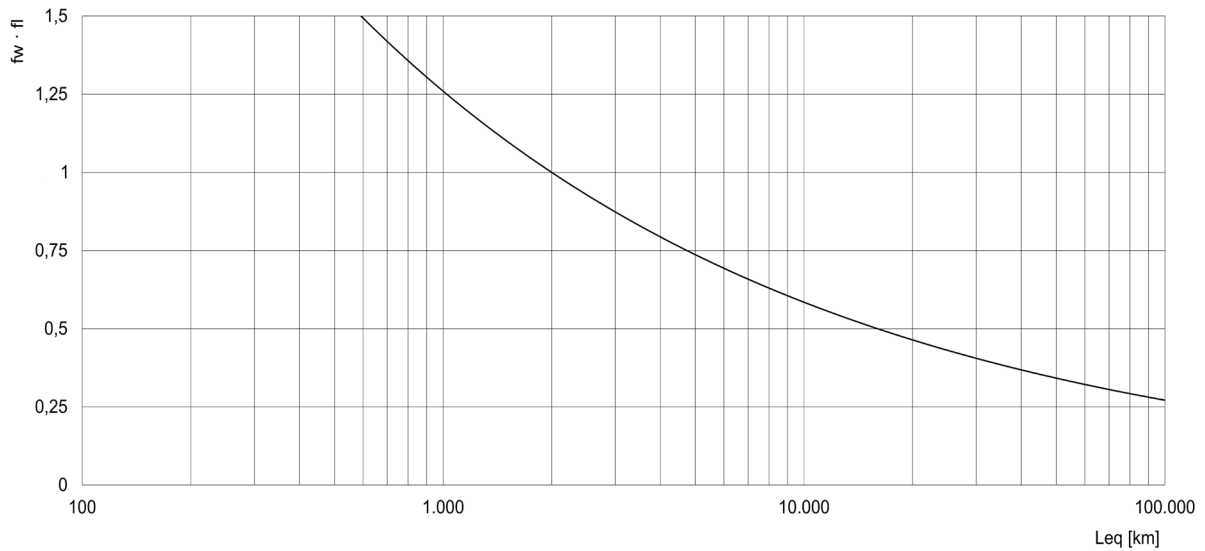

SAFETY COEFFICIENT OF THE GUIDE f_w			
APPLICATION	ACCELERATION [m/s ²]	SPEED [m/s]	COEFFICIENT f_w
light	< 10	< 1	1 ÷ 1,5
normal	10 ÷ 25	1 ÷ 2	1,5 ÷ 2,5
heavy	> 25	> 2	2,5 ÷ 3,5

HOW TO CALCULATE THE SERVICE LIFE OF THE RECIRCULATING BALL SCREW

To perform a correct dimensioning of the Series 5ES...BS cylinder, you need to consider some facts.

Among these, the most important are:

- Dynamics of the system
- Operation and pause cyclicality
- Work environment
- General performance requirements: repeatability, accuracy, precision, etc.

CALCULATE THE LIFE IN ROTATIONS

where:

L_r = Life of the cylinder in number of rotations of the BS ball screw

C = Dynamic load coefficient of the cylinder [N]

F = Average axial force applied [N]

f_w = Safety coefficient according to the working conditions

$$L_r = \left(\frac{C}{F_m \cdot f_w} \right)^3 \cdot 10^6$$

CALCULATION OF LIFE IN km

where:

L_{km} = Life of the cylinder in km [km]

p = pitch of the BS ball screw [mm]

$$L_{km} = \frac{L_r \cdot p}{10^6}$$

CALCULATION OF THE LIFE IN HOURS

where:

L_h = Life of the cylinder in hours

n_m = average number of revolutions of the RDS ball screw [rpm]

$$L_h = \frac{L_r}{n_m \cdot 60}$$

SAFETY COEFFICIENT OF THE SCREW f_w				
APPLICATION	ACCELERATION [m/s ²]	SPEED [m/s]	DUTY CYCLE	COEFFICIENT f_w
normal	5,0 ÷ 15,0	0,5 ÷ 1,0	35% ÷ 65%	1,25 ÷ 1,5
light	< 5,0	< 0,5	< 35%	1,0 ÷ 1,25
heavy	> 15,0	> 1,0	> 65%	1,5 ÷ 3,0

HOW TO CALCULATE THE SERVICE LIFE OF 5ES065BS10P0750AS1 - VERTICAL MOUNTING

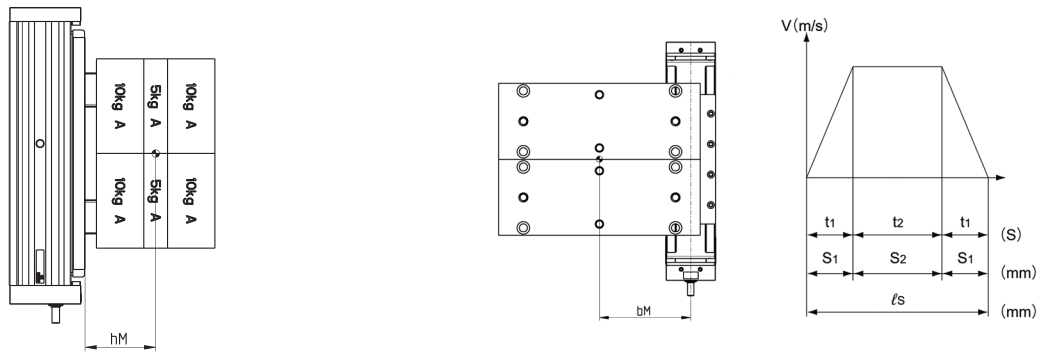

Application data:

$M = 50 \text{ kg}$

$b_M = 120 \text{ mm}$

$h_M = 79,5 \text{ mm}$

$f_w \text{ guide} = 1,5$

$\text{acc} = \text{dec} = 10 \text{ m/s}^2$

$\text{vel} = 0,3 \text{ m/s}$

$S_1 = S_3 = 4.5 \text{ mm}; l_s = 750 \text{ mm}$

$f_w \text{ screw} = 1,25$

How to calculate the applied loads of the guideway

$$F_y = 0 \text{ N}$$

$$F_z = 0 \text{ N}$$

$$M_{x_{1,2,3}} = 0 \text{ Nm}$$

$$M_{y_1} = F_x \cdot (h_M + h) = M \cdot (g + a) \cdot (h_M + h) = 50 \cdot (9.81 + 10) \cdot (0.056 + 0.0795) = 134.2 \text{ Nm}$$

$$M_{y_2} = F_x \cdot (h_M + h) = M \cdot (g + a) \cdot (h_M + h) = 50 \cdot (9.81 + 0) \cdot (0.056 + 0.0795) = 66.5 \text{ Nm}$$

$$M_{y_3} = F_x \cdot (h_M + h) = M \cdot (g + a) \cdot (h_M + h) = 50 \cdot (9.81 - 10) \cdot (0.056 + 0.0795) = 1.3 \text{ Nm}^*$$

$$M_{z_1} = F_x \cdot b_M = M \cdot (g + a) \cdot b_M = 50 \cdot (9.81 + 10) \cdot 0.12 = 118.9 \text{ Nm}$$

$$M_{z_2} = F_x \cdot b_M = M \cdot (g + a) \cdot b_M = 50 \cdot (9.81 + 0) \cdot 0.12 = 58.9 \text{ Nm}$$

$$M_{z_3} = F_x \cdot b_M = M \cdot (g + a) \cdot b_M = 50 \cdot (9.81 - 10) \cdot 0.12 = 1.14 \text{ Nm}^*$$

$$M_y = \sqrt[3]{\frac{1}{750} \cdot (134.2^3 \cdot 4.5 + 66.5^3 \cdot 741 + 1.3^3 \cdot 4.5)} = 67.3 \text{ Nm}$$

$$M_z = \sqrt[3]{\frac{1}{750} \cdot (118.9^3 \cdot 4.5 + 58.9^3 \cdot 741 + 1.14^3 \cdot 4.5)} = 59.6 \text{ Nm}$$

$$f_l = \frac{|F_y|}{F_{y,eq}} + \frac{|F_z|}{F_{z,eq}} + \frac{|M_x|}{M_{x,eq}} + \frac{|M_y|}{M_{y,eq}} + \frac{|M_z|}{M_{z,eq}} = \frac{0}{8300} + \frac{0}{8300} + \frac{67.3}{324} + \frac{59.6}{324} + \frac{0}{55} = 0.392$$

*NB: Positive sign because for each phase the values are considered in absolute value

Graph of the service life of the guide

Once the f_l value has been calculated, the service life value can be obtained from the graph or by using the formula:

$$Leq = \left(\frac{1}{f_l \cdot f_w} \right)^3 \times 2000 = \left(\frac{1}{0.392 \cdot 1.5} \right)^3 \times 2000 = 9838 \text{ km}$$

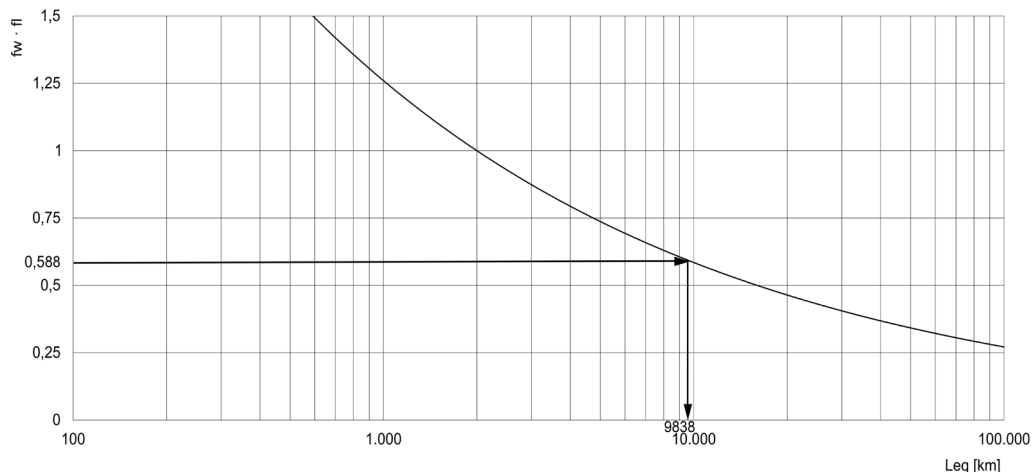

How to calculate the service life of the screw

$$Fx_1 = 50 \cdot (9.81 + 10) = 990.5 \text{ N}$$

$$Fx_1 = 50 \cdot (9.81 + 0) = 490.5 \text{ N}$$

$$Fx_1 = 50 \cdot (9.81 - 10) = 9.5 \text{ N}$$

$$Fx_m = \sqrt[3]{\frac{1}{ls} \cdot (Fx_1^3 \cdot s1 + Fx_2^3 \cdot s2 + Fx_3^3 \cdot s3 + \dots + Fx_n^3 \cdot sn)} =$$

$$\sqrt[3]{\frac{1}{750} \cdot (990.5^3 \cdot 4.5 + 490.5^3 \cdot 741 + 9.5^3 \cdot 4.5)} = 496.5 \text{ N}$$

$$Lr = \left(\frac{C}{Fm \cdot fw} \right)^3 \cdot 10^6 = \left(\frac{4400}{496.5 \cdot 1.25} \right)^3 \cdot 10^6 = 356.345 \cdot 10^6$$

$$L_{km} = \frac{Lr \cdot p}{10^6} = \frac{206.218 \cdot 10^6 \cdot 10}{10^6} = 3563.5 \text{ km}$$

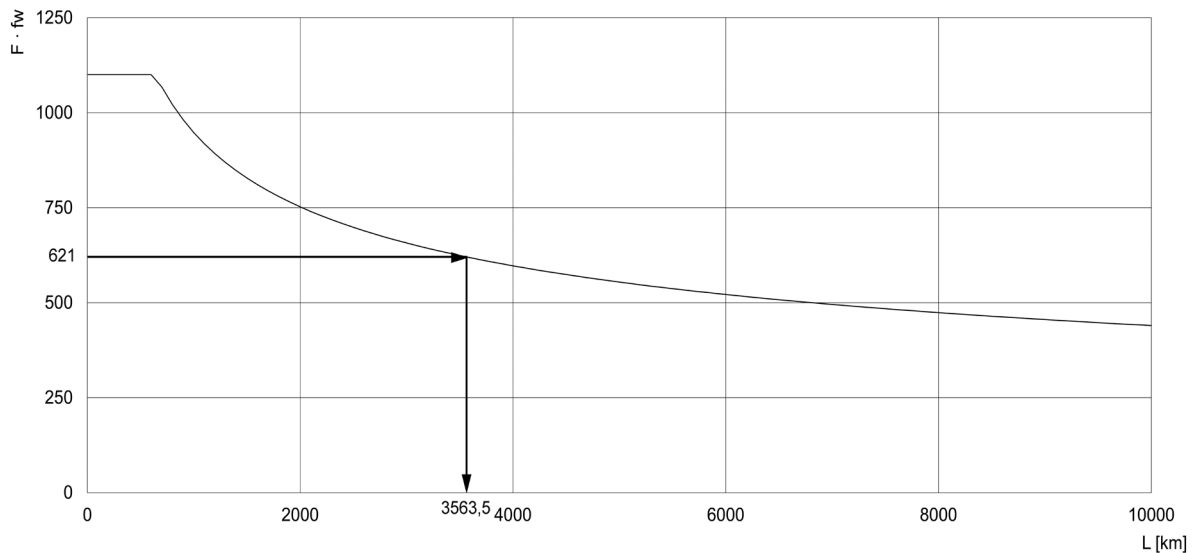

How to calculate the service life of the actuator

For a correct dimensioning of the 5E axis, used individually or in a cartesian system with several axes, it is necessary to calculate the service life of its main components: screw and guide. The expected life of the actuator is the same as the life of the component with the shortest service life. In this case the service life of the actuator will be 3563.5 km due to the fact that the component that will submit damage first will be the recirculating ball screw.

HOW TO CALCULATE THE DRIVING TORQUE [Nm]

F_e = Total force acting from outside [N]

m_e = Mass of the body to move [kg]

p = Pitch of the ball screw [mm]

η = Performance

C_{M1} = Driving torque due to external agents [Nm]

$$C_{TOT} = C_{M1} + C_{M2} + C_{M3}$$

$$C_{M1} = \frac{F_e \cdot p}{2\pi \cdot 1000} \cdot \frac{1}{\eta}$$

J_{TOT} = Moment of inertia of rotating components [kg·m²]

J_F = Moment of inertia of fixed-length rotating components [kg·m²]

J_V = Moment of inertia of variable-length rotating components [kg·m²]

K_V = Coefficient of inertia of variable-length rotating components [kg·mm²/mm]

C = Rod stroke [mm]

$\dot{\omega}$ = Angular acceleration [rad/s²]

a = Linear acceleration of the ball screw [m/s²]

C_{M2} = Driving torque due to rotating components [Nm]

$$J_{TOT} = (J_F + J_V) \cdot 10^{-6}$$

$$J_V = K_V \cdot C$$

$$\dot{\omega} = \frac{a \cdot 2\pi \cdot 1000}{p}$$

$$C_{M2} = J_{TOT} \cdot \dot{\omega} \cdot \frac{1}{\eta}$$

F_{TT} = Force needed to move sliding components [N]

m_{c1} = Mass of the fixed-length sliding components [kg]

C_{M3} = Driving torque due to sliding components [Nm]

$$F_{TT} = m_{c1} \cdot a$$

$$C_{M3} = \frac{F_{TT} \cdot p}{2\pi \cdot 1000} \cdot \frac{1}{\eta}$$

Values of mass and of fixed and rotating moments of inertia of 5E components				
Size	Mod.	J_f [kg·mm ²]	K_V [kg·mm ² /mm]	m_{c1} [kg]
50	AS1	13,67	0,02	0,552
50	AC1	13,03	0,02	0,419
50	DS1	-	-	0,445
50	DC1	-	-	0,311
65	AS1	20,38	0,02	1,197
65	AC1	19,68	0,02	0,817
65	DS1	-	-	1,089
65	DC1	-	-	0,709
80	AS1	34,97	0,05	2,295
80	AC1	31,5	0,05	1,552
80	DS1	-	-	2,099
80	DC1	-	-	1,356

Life of the axis according to the average axial force applied

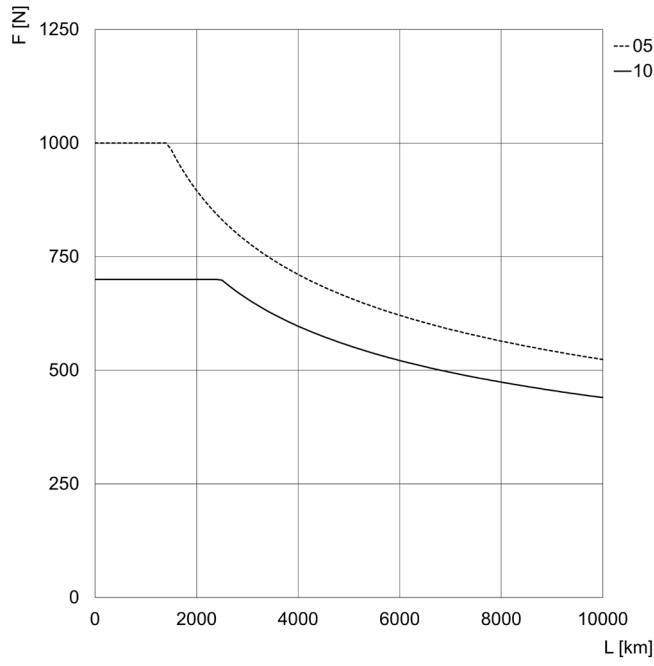

Size 050

F = Axial Force [N]
L = life [km]
Curves calculated with $f_w = 1$

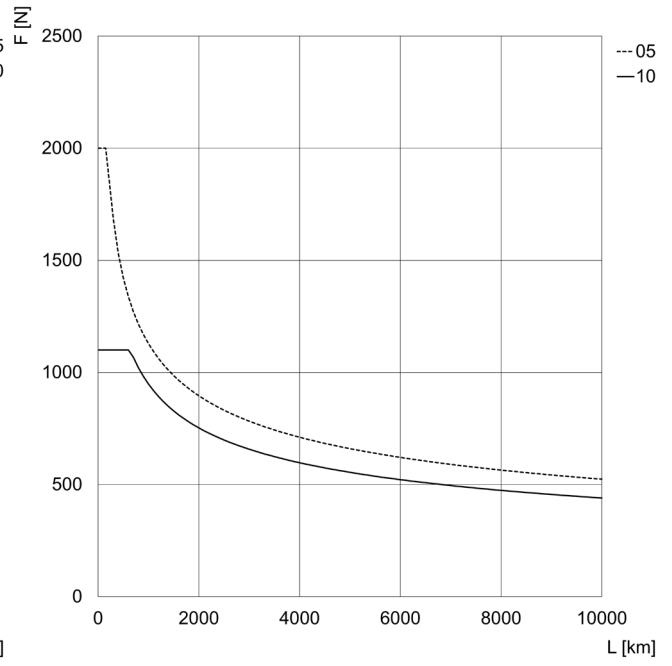

Size 065

F = Axial Force [N]
L = life [km]
Curves calculated with $f_w = 1$

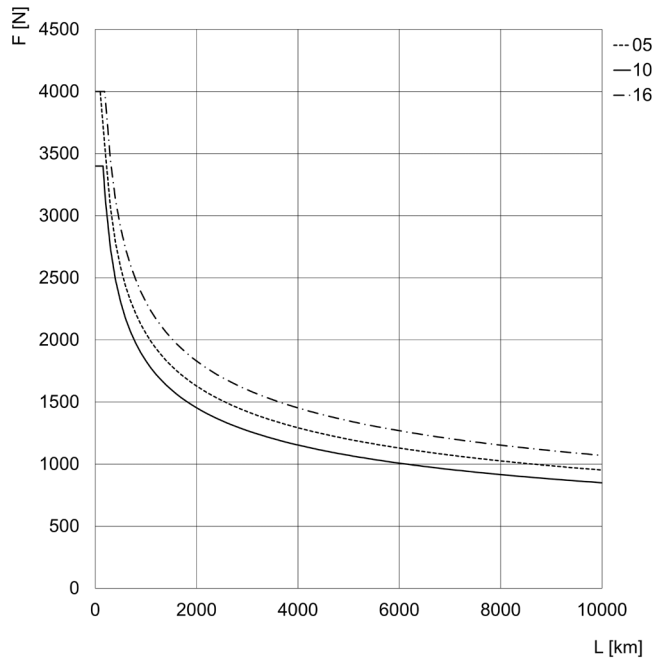

Size 080

F = Axial Force [N]
L = life [km]
Curves calculated with $f_w = 1$

Maximum compressive load* as a function of stroke

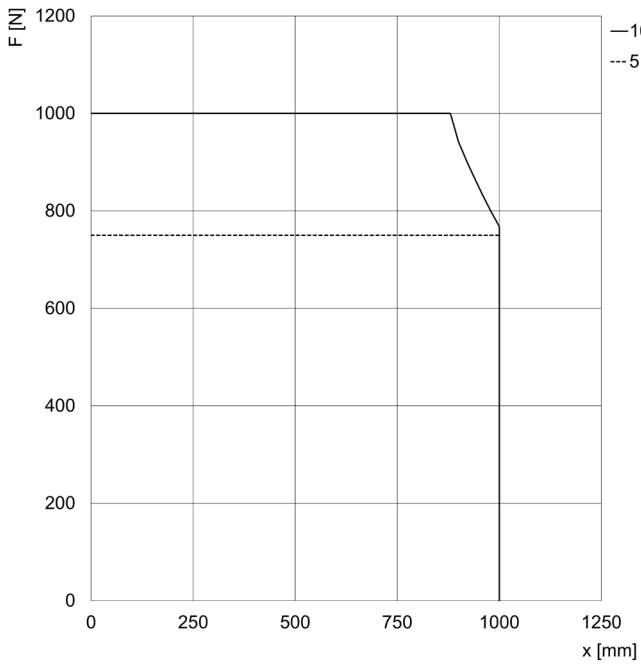

Size 050

F = Axial Force [N]
x = Slider position [mm]

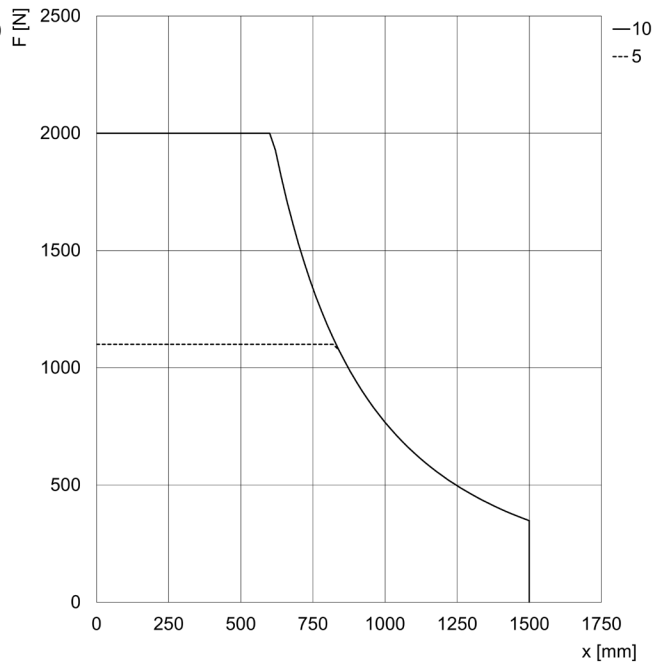

Size 065

F = Axial Force [N]
x = Slider position [mm]

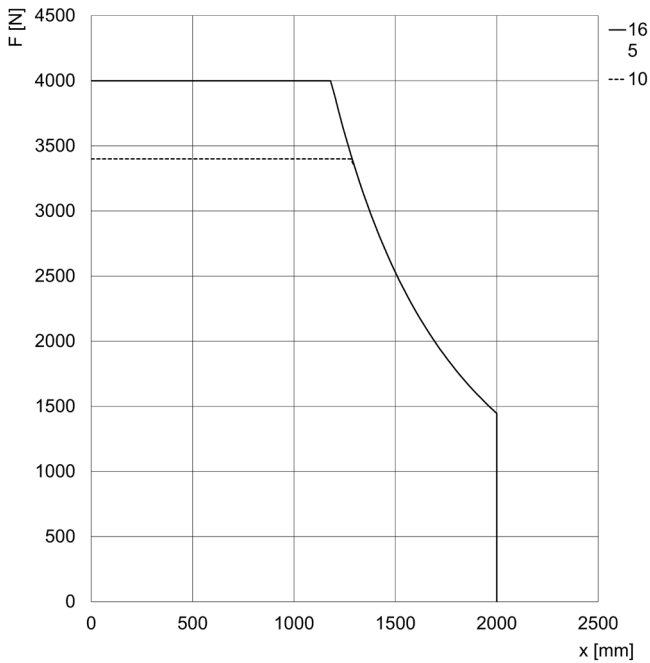

Size 080

F = Axial Force [N]
x = Slider position [mm]

*Force applied towards the motor

Maximum speed of the axis according to its stroke

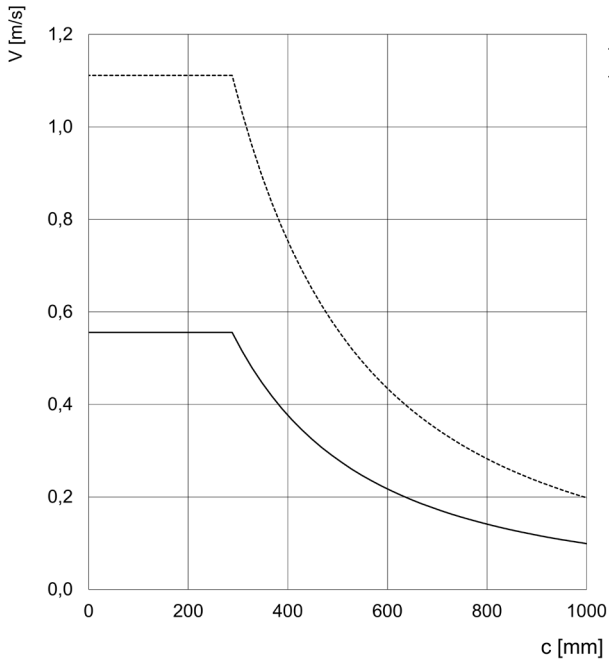

Size 050

V = speed [m/s]
c = stroke [mm]

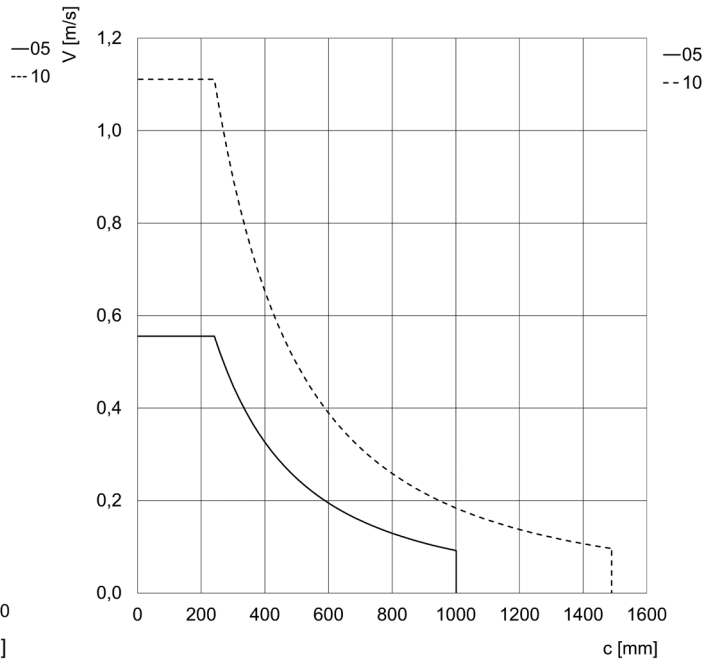

Size 065

V = speed [m/s]
c = stroke [mm]

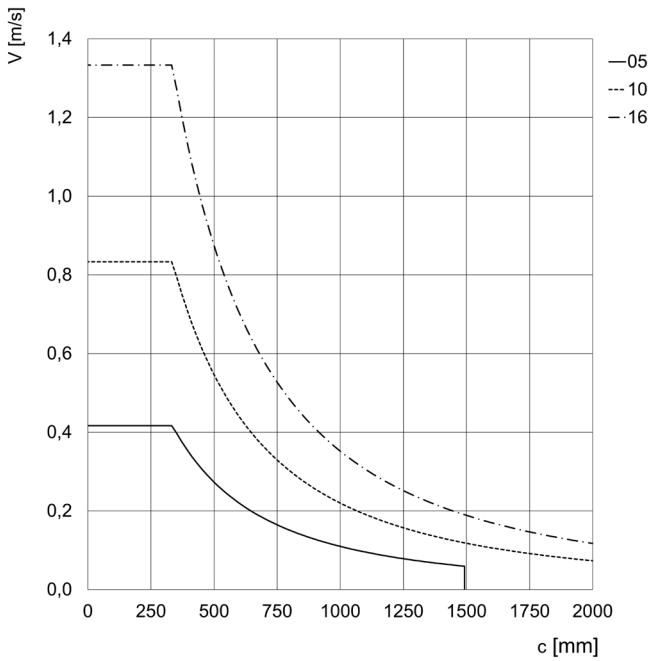

Size 080

V = speed [m/s]
c = stroke [mm]

Deflection according to the distance of the supports - Version A

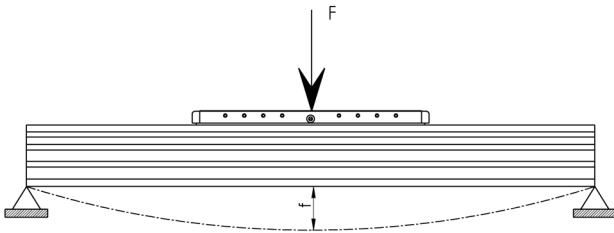

$$f_{max} = c_{max} \cdot 5 \cdot 10^{-4}$$

f_{max} = Maximum admissible deflection [mm]
 c_{max} = Maximum stroke of axis 5E [mm]

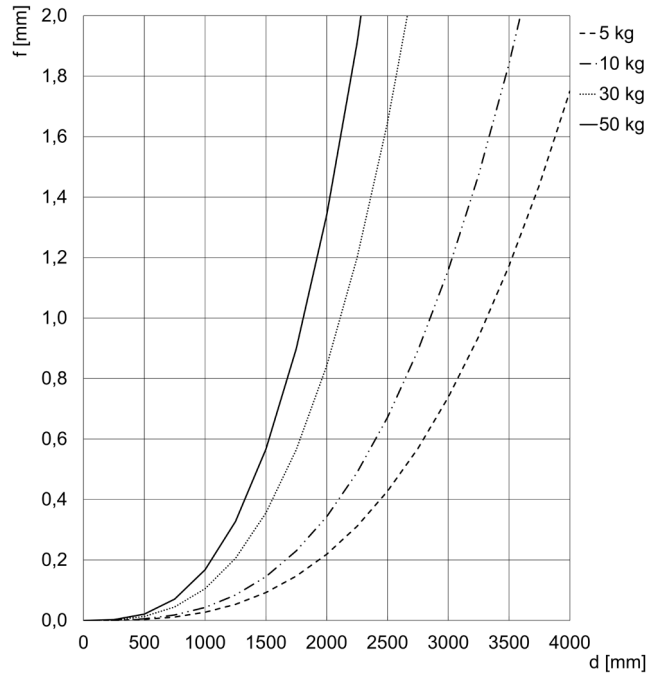

Size 050

f = deflection generated between the supports [mm]
 d = distance between the supports [mm]

SERIES 5ES...BS ELECTROMECHANICAL AXIS

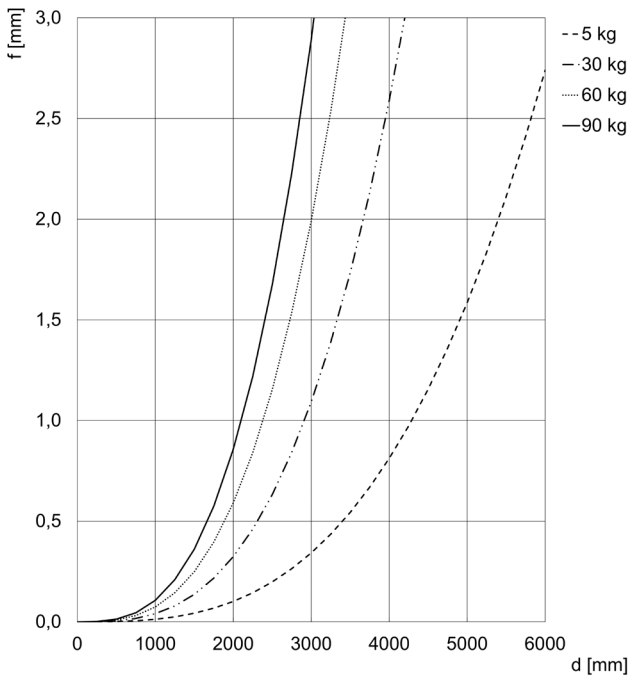

Size 065

f = deflection generated between the supports [mm]
 d = distance between the supports [mm]

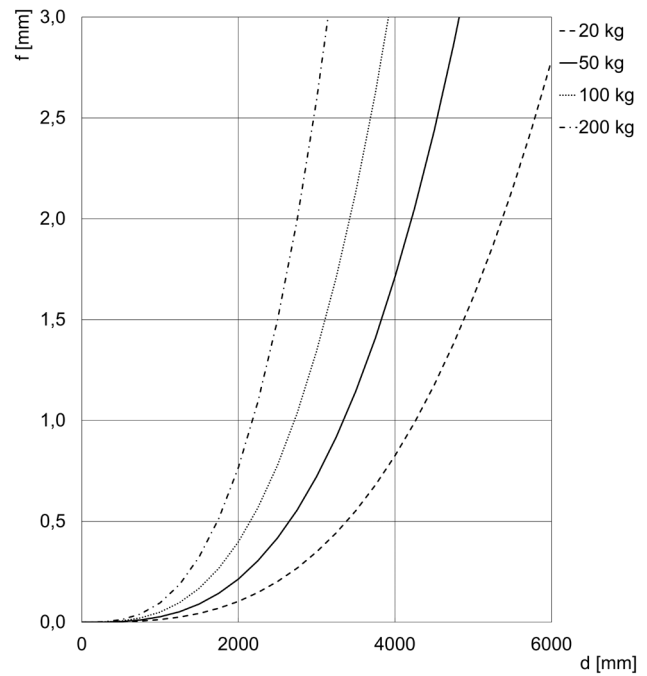

Size 080

f = deflection generated between the supports [mm]
 d = distance between the supports [mm]

ACCESSORIES FOR SERIES 5ES...BS



Side clamping bracket
Mod. BGS



Perforated side clamping
bracket Mod. BGA

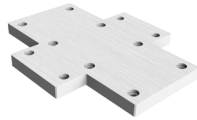

Interface plate - slider on
slider



Interface plate - profile
on slider



Interface plate - profile on
slider - long arm

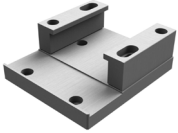

Interface plate - Series 6E
cylinder on slider



Interface plate - profile
side on slider, left pos.



Interf. plate - profile side
on slider, right pos.

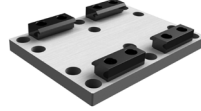

Fixed interface plate

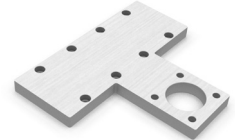

Interface plate -
Guide S. 45 / Cyl. S. 6E

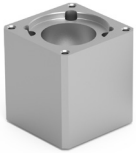

Kit for axial connection
Mod. AM



Kit for parallel connection
Mod. PM

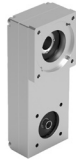

Nuts for slots



5E/5V connection flange



Centering ring
Mod. TR-CG

SERIES 5ES...BS ELECTROMECHANICAL AXIS

Electromechanical axis Mod. AS1

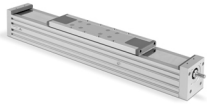

+ = add the stroke

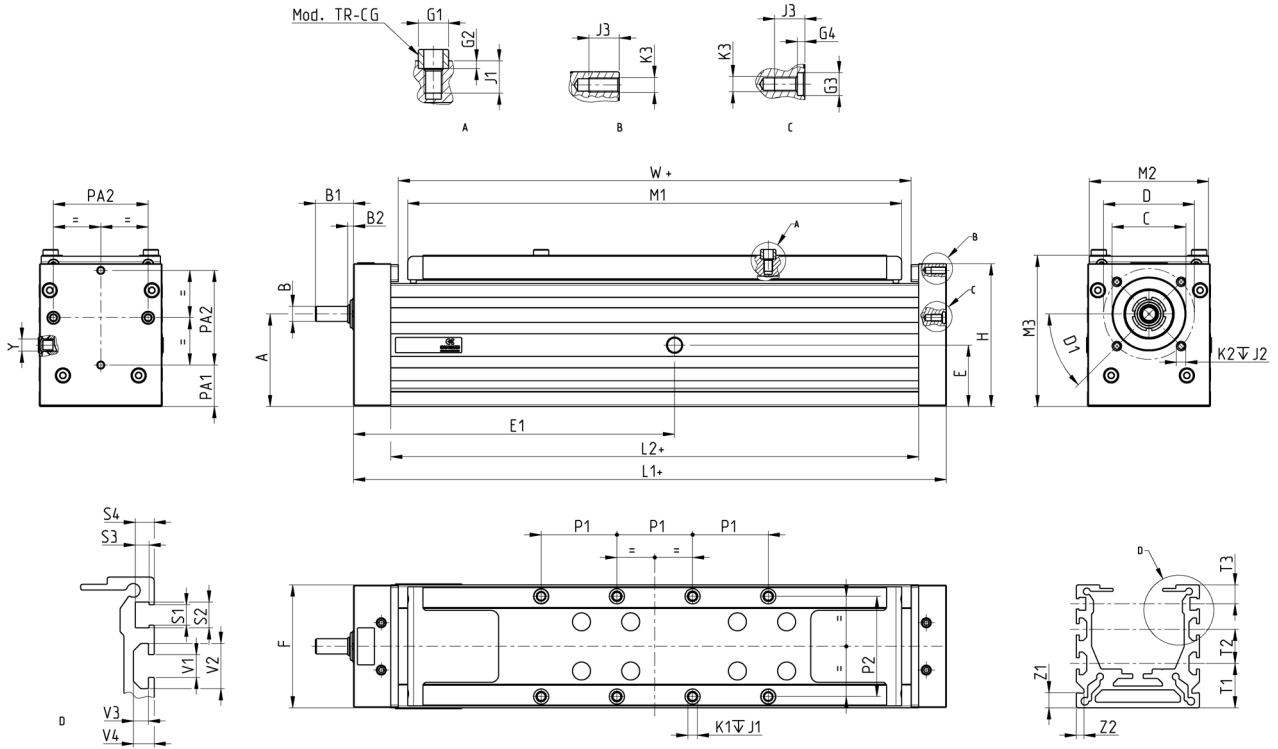

NOTE:

- Dimension T2 in size 50 is not indicated because there is only one slot.
- Dimension Y indicates the hole for centralized lubrication by means of grease.

Size	A	B ^(H7)	B1	B2	C	D	D1	E	E1	F	G1 ^(H8)	G2	G3 ^(H8)	G4	H	K1	J1	K2	J2	K3	J3	L1	L2	M1	M2	M3	P1	P2	PA1	PA2	T1	T2	T3	V	W	Y ●	Z1	Z2
50	36,7	8	22,3	5,3	30	38	90*	32	141	50	6	2	6	2	60,5	M4	7,5	M4	6	M4	6	264	232	214	48	65	30	40	16,7	40	20	■	10	6	224	6,3	8	4
65	49	8	20,2	3,2	38	48	45*	32,5	169,6	65	8	2	6	2	75,5	M5	8	M4	6	M4	6	313,5	279	261	63	80	40	53	22	50	23,5	18	10	6	271	6,3	8	4
80	62	10	21,3	0,3	55	65	45*	38	219	80	10	3	8	2	94,5	M6	12	M5	10	M5	10	410,5	368	350	78	100	55	64	30	60	25	25	10	8	360	6,3	8	4

Size	WEIGHT STROKE ZERO [kg]	STROKE WEIGHT PER METER [kg/m]
50	2,00	4,07
65	3,55	6,03
80	6,75	9,85

Electromechanical axis Mod. DS1



+ = add the stroke

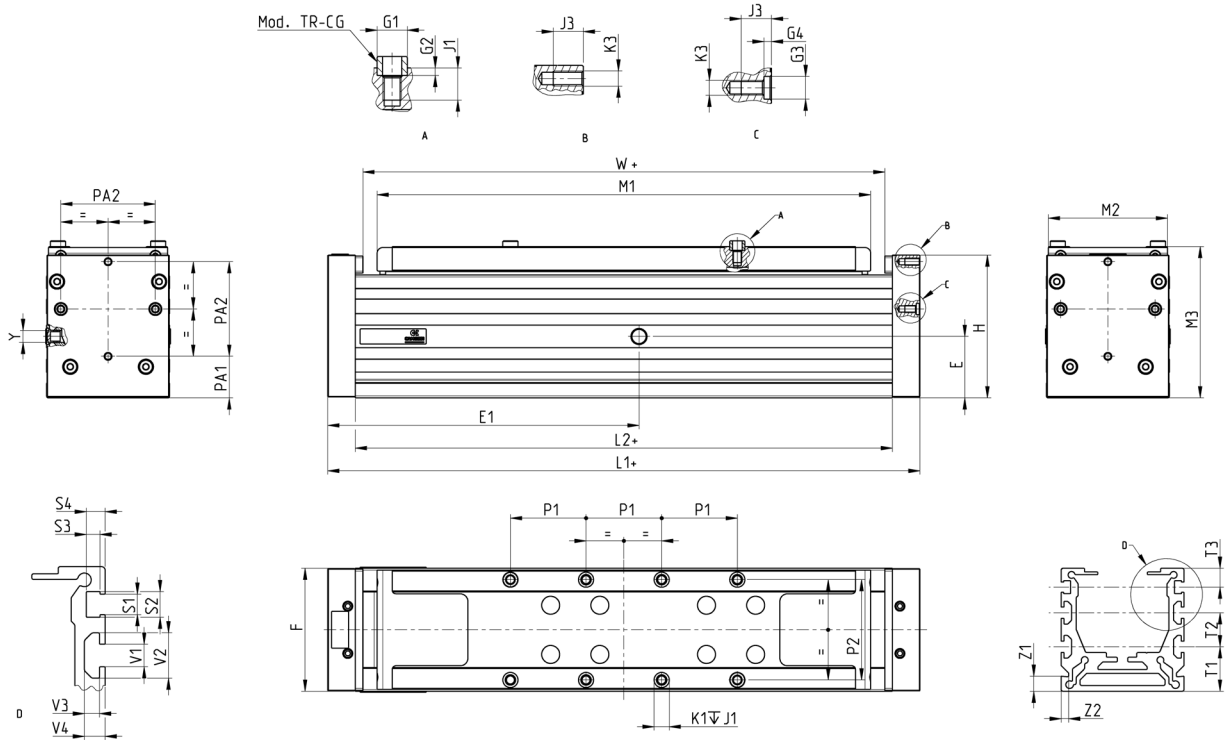

NOTE:

- Dimension T2 in size 50 is not indicated because there is only one slot.
- Dimension Y indicates the hole for centralized lubrication by means of grease.

Size	A	B ^(H7)	B1	B2	C	D	D1	E	E1	F	G1 ^(H8)	G2	G3 ^(H8)	G4	H	K1	J1	K2	J2	K3	J3	L1	L2	M1	M2	M3	P1	P2	PA1	PA2	T1	T2	T3	V	W	Y●	Z1	Z2
50	-	-	-	-	-	-	-	32	138	50	6	2	6	2	61	M4	7,5	-	-	M4	6	264	235	214	48	65	30	40	16,7	40	20	■	10	6	227	6,3	8	4
65	-	-	-	-	-	-	-	33	165	65	8	2	6	2	76	M5	8	-	-	M4	6	313,5	284	261	63	80	40	53	22	50	23,5	18	10	6	276	6,3	8	4
80	-	-	-	-	-	-	-	38	213	80	10	3	8	2	95	M6	12	-	-	M5	10	410,5	374,5	350	78	100	55	64	30	60	25	25	10	8	366,5	6,3	8	4

Size	WEIGHT STROKE ZERO [kg]	STROKE WEIGHT PER METER [kg/m]
50	1,34	3,18
65	2,77	5,12
80	5,52	8,21

Electromechanical axis Mod. AC1

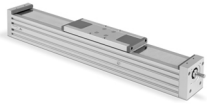

+ = add the stroke

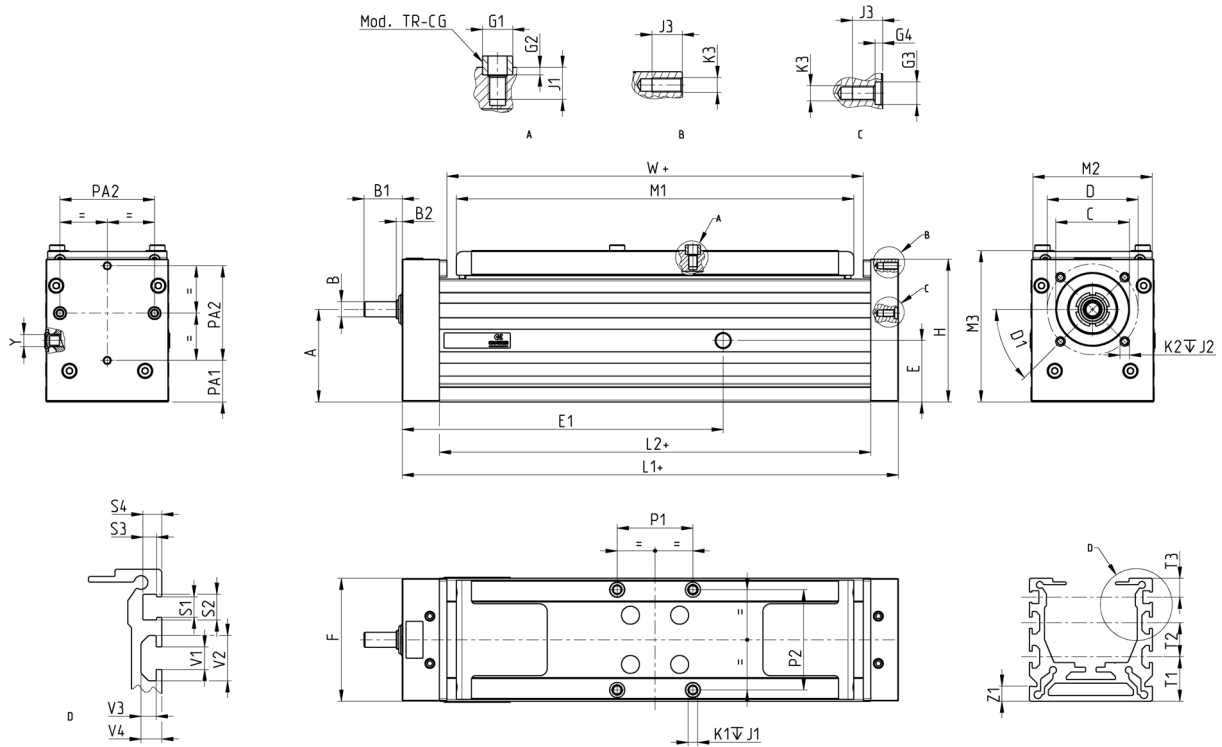

NOTE:

- Dimension T2 in size 50 is not indicated because there is only one slot.
- Dimension Y indicates the hole for centralized lubrication by means of grease.

Size	A	B ^(H7)	B1	B2	C	D	D1	E	E1	F	G1 ^(H8)	G2	G3 ^(H8)	G4	H	K1	J1	K2	J2	K3	J3	L1	L2	M1	M2	M3	P1	P2	PA1	PA2	T1	T2	T3	V	W	Y ●	Z1	Z2
50	36,7	8	22,3	5,3	30	38	90 [±]	32	141	50	6	2	6	2	61	M4	7,5	M4	6	M4	6	224	192	174	48	65	30	40	16,7	40	20	■	10	6	184	6,3	8	4
65	49	8	20,2	3,2	38	48	45 [±]	33	170	65	8	2	6	2	76	M5	8	M4	6	M4	6	262	228	210	63	80	40	53	22	50	23,5	18	10	6	220	6,3	8	4
80	62	10	21,3	0,3	55	65	45 [±]	38	219	80	10	3	8	2	95	M6	12	M5	10	M5	10	341,5	299	281	78	100	55	64	30	60	25	25	10	8	291	6,3	8	4

Size	WEIGHT STROKE ZERO [kg]	STROKE WEIGHT PER METER [kg/m]
50	1,68	4,07
65	2,82	6,03
80	5,25	9,85

Electromechanical axis Mod. DC1

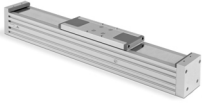

+ = add the stroke

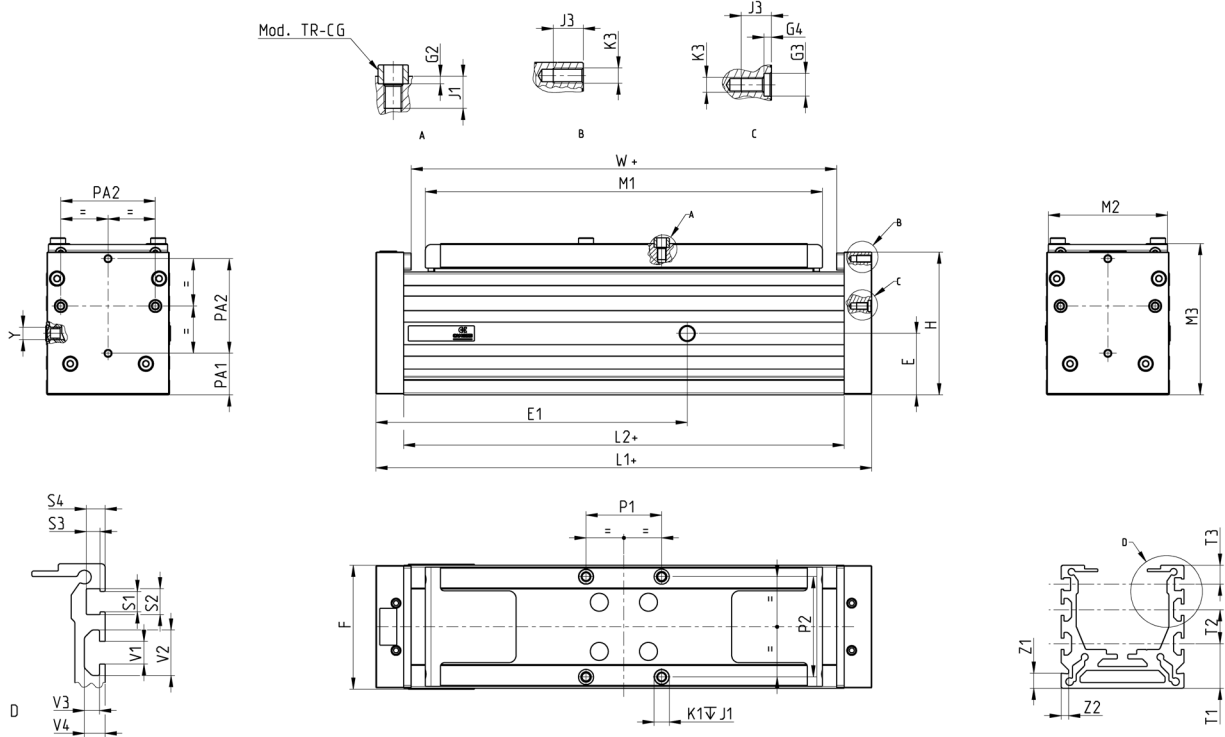

NOTE:

- Dimension T2 in size 50 is not indicated because there is only one slot.
- Dimension Y indicates the hole for centralized lubrication by means of grease.

Size	A	B ^(M7)	B1	B2	C	D	D1	E	E1	F	G1 ^(M8)	G2	G3 ^(M8)	G4	H	K1	J1	K2	J2	K3	J3	L1	L2	M1	M2	M3	P1	P2	PA1	PA2	T1	T2	T3	V	W	Y●	Z1	Z2
50	-	-	-	-	-	-	-	32	138	50	6	2	6	2	61	M4	7,5	-	-	M4	6	224	195	174	48	65	30	40	16,7	40	20	■	10	6	187	6,3	8	4
65	-	-	-	-	-	-	-	33	165	65	8	2	6	2	76	M5	8	-	-	M4	6	262	233	210	63	80	40	53	22	50	23,5	18	10	6	225	6,3	8	4
80	-	-	-	-	-	-	-	38	213	80	10	3	8	2	95	M6	12	-	-	M5	10	341,5	306	281	78	100	55	64	30	60	25	25	10	8	297,5	6,3	8	4

Size	WEIGHT STROKE ZERO [kg]	STROKE WEIGHT PER METER [kg/m]
50	1,06	3,18
65	2,08	5,12
80	4,13	8,21

Side clamping bracket Mod. BGS

Material: Aluminium



Supplied with:
2x clamps

TABLE NOTE:
* according to the span
(max admissible deflection)
recommended value 500
mm

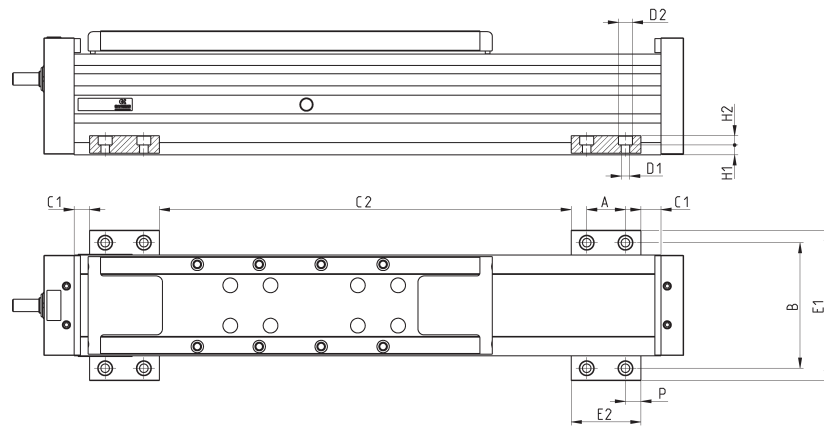

Mod.	Size	A	B	C1	C2	$\varnothing D1$	$\varnothing D2$	E1	E2	H1	H2	P	Weight (g)
BGS-5E-M5	50	25	66	10	*	5,5	9	82	45	6,4	6	10	45
BGS-5E-M5	65	25	81	10	*	5,5	9	97	45	6,4	6	10	45
BGS-5E-M5	80	25	96	10	*	5,5	9	112	45	6,4	6	10	45
BGS-5E-M6	50	25	66	10	*	6,5	10,5	82	45	5,4	7	10	40
BGS-5E-M6	65	25	81	10	*	6,5	10,5	97	45	5,4	7	10	40
BGS-5E-M6	80	25	96	10	*	6,5	10,5	112	45	5,4	7	10	40

Perforated side clamping bracket Mod. BGA

Material: Aluminium



Supplied with:
2x clamps with perforation

TABLE NOTE:
* according to the span
(max admissible deflection)
recommended value 500
mm

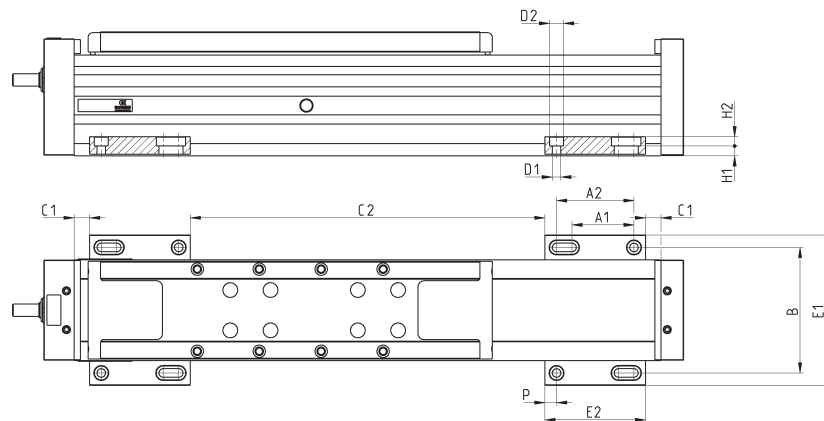

Mod.	Size	A1	A2	B	C1	C2	$\varnothing D1$	$\varnothing D2$	E1	E2	H1	H2	P	Weight (g)
BGA-5E-M5	50	40	50	66	10	*	5,5	9	82	65	6,4	6	7,5	60
BGA-5E-M5	65	40	50	81	10	*	5,5	9	97	65	6,4	6	7,5	60
BGA-5E-M5	80	40	50	96	10	*	5,5	9	112	65	6,4	6	7,5	60
BGA-5E-M6	50	40	50	66	10	*	6,5	10,5	82	65	5,4	7	7,5	55
BGA-5E-M6	65	40	50	81	10	*	6,5	10,5	97	65	5,4	7	7,5	55
BGA-5E-M6	80	40	50	96	10	*	6,5	10,5	112	65	5,4	7	7,5	55

Interface plate - slider on slider



The kit includes:
1x interface plate
8x screws + 8x lock washers to connect the plate on the slider of the main axis
4x screws + 4x lock washers to connect the plate on the slider of the secondary axis

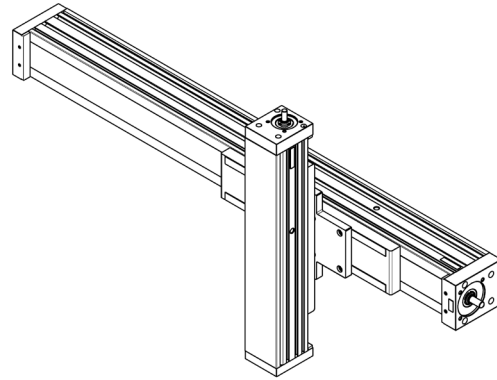
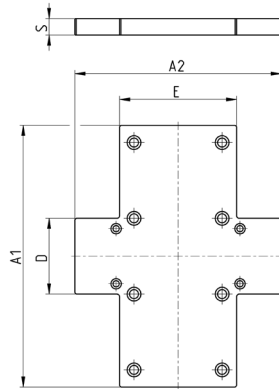

Mod.	Size	A1	A2	D	E	S	Weight (g)
XY-S65-S50	65	150	150	55	70	12	515
XY-S80-S50	80	190	150	55	85	12	690
XY-S80-S65	80	190	150	70	85	12	720

Interface plate - profile on slider



The kit includes:
1x interface plate
8x screws + 8x lock washers to connect the plate on the slider of the main axis
4x clamps
8x screws + 8x lock washers to connect the secondary axis on the plate by means of clamps

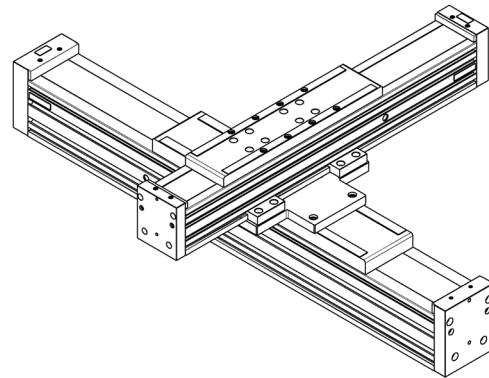
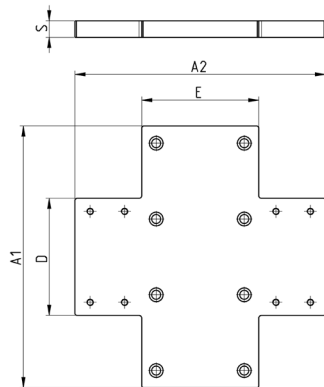

Mod.	Size	A1	A2	D	E	S	Weight (g)
XY-S65-P50	65	150	162	85	70	12	730
XY-S80-P50	80	190	182	85	85	12	945
XY-S80-P65	80	190	185	100	85	12	1000

Interface plate - profile on slider - long arm



The kit includes:
 1x interface plate
 8x screws + 8x lock washers
 to connect plate on the slider
 of the main axis
 4x clamps
 8x screws + 8x lock washers
 to connect plate on the slider
 of the secondary axis by
 means of clamps

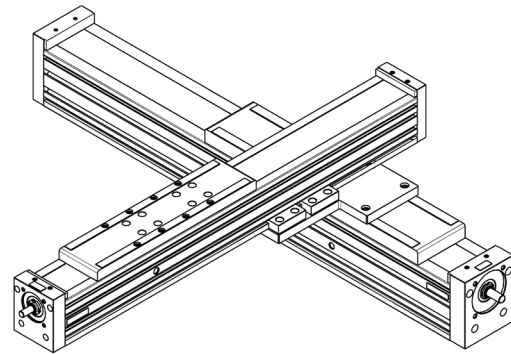
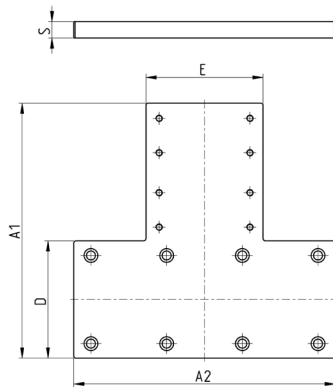

Mod.	Size	A1	A2	D	E	S	Weight (g)
XY-S50-P50-T	50	162	130	50	85	12	600
XY-S65-P50-T	65	170	150	65	85	12	750
XY-S65-P65-T	65	185	170	65	100	12	800
XY-S80-P50-T	80	185	190	85	85	12	960
XY-S80-P65-T	80	185	190	85	100	12	1010
XY-S80-P80-T	80	200	190	85	120	12	1100

Interface plate - Series 6E cylinder on slider

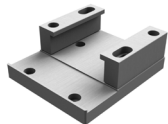

The kit includes:
 1x interface plate
 4x screws + 4x lock washers
 to connect the plate on the
 slider of the axis
 2x clamps
 4x screws + 4x lock washers
 to fix the Series 6E cylinder
 by means of clamps

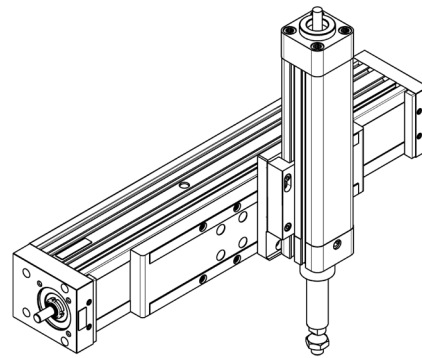
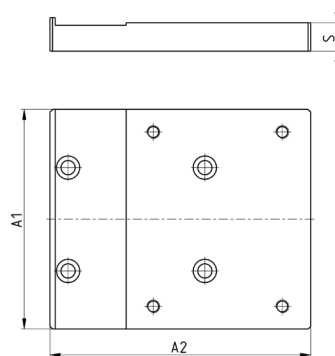

Mod.	Size	A1	A2	S	Weight (g)
XY S50-6E32	50	72	101	11	315
XY-S65-6E32	65	72	101	11	315
XY-S65-6E40	65	85	101	11	350
XY S65-6E50	65	95	110	12	510
XY-S80-6E32	80	75	101	12	385
XY-S80-6E40	80	85	101	12	410
XY-S80-6E50	80	95	110	12	510
XY S80-6E63	80	106	110	12	560

Interface plate - profile side on slider - left position



The kit includes:
1x interface plate
8x screws + 8x lock washers to connect the plate on the slider of the main axis, screws and nuts for slot to connect the plate on the slider of the secondary axis

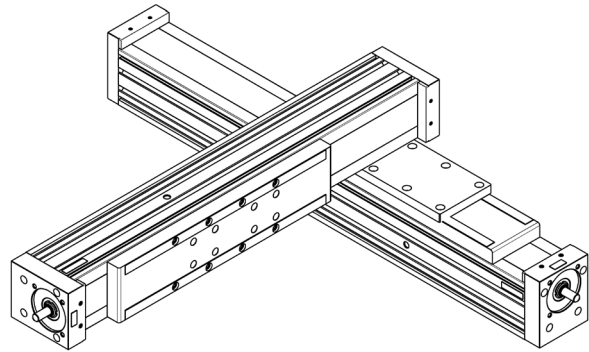
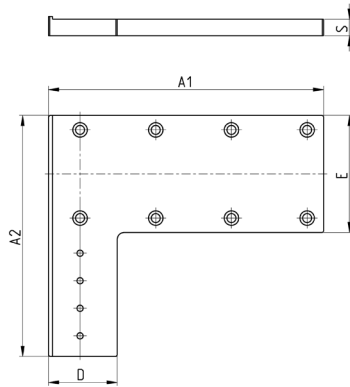

Mod.	Size	A1	A2	D	E	S	Nr of holes	Weight (g)
XY-S50-LL50	50	130	145	50	55	11	4	450
XY-S65-LL50	65	160	160	50	70	11	4	500
XY-S65-LL65	65	170	180	65	70	12	8	550
XY-S80-LL50	80	200	175	50	85	12	4	750
XY-S80-LL65	80	210	195	65	85	12	8	870
XY-S80-LL80	80	210	195	80	85	12	8	900

Interface plate - profile side on slider - right position



The kit includes:
1x interface plate
8x screws + 8x lock washers to connect the plate on the slider of the main axis, screws and nuts for slot to connect the plate on the slider of the secondary axis

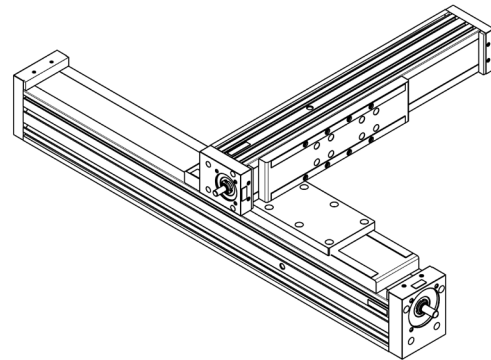
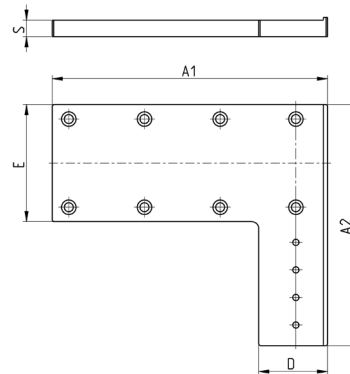

Mod.	Size	A1	A2	D	E	S	Nr of holes	Weight (g)
XY-S50-LR50	50	130	145	50	55	11	4	450
XY-S65-LR50	65	160	160	50	70	11	4	500
XY-S65-LR65	65	170	180	65	70	12	8	550
XY-S80-LR50	80	200	175	50	85	12	4	750
XY-S80-LR65	80	210	195	65	85	12	8	870
XY-S80-LR80	80	210	195	80	85	12	8	900

Interface plate - Anti-rotation guides S. 45 / Cylinders S. 6E on slider

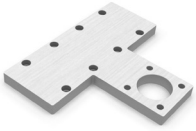

The kit includes:
 1x interface plate
 8x screws + 8x lock washers
 to connect the plate on the
 slider
 4x screws to connect the
 cylinder

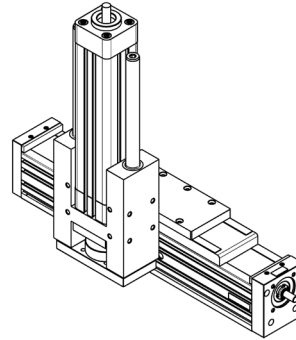
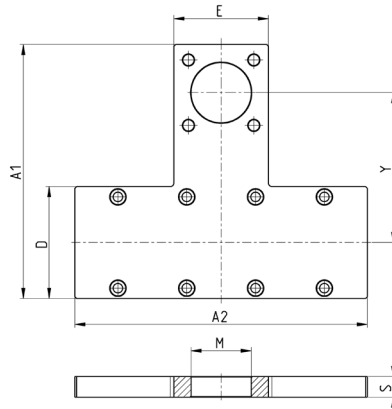

Mod.	Size	A1	A2	D	E	S	$M^{(H10)}$	Y	Weight (g)
XY-S50-45N32	50	124	130	50	49	12	30	75	350
XY-S65-45N32	65	139	170	65	49	12	30	82,5	480
XY-S65-45N40	65	147,5	170	65	55	12	35	87	500
XY-S65-45N50	65	157	170	65	66,5	12	40	91,5	530
XY-S80-45N40	80	167,5	190	85	55	12	35	97	660
XY-S80-45N50	80	177	190	85	65	12	40	101,5	690
XY-S80-45N63	80	190,5	190	85	75	12	45	110	740

Fixed interface plate

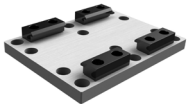

The kit includes:
 1x interface plate
 4x clamps
 8x screws to connect the
 clamps on the plate

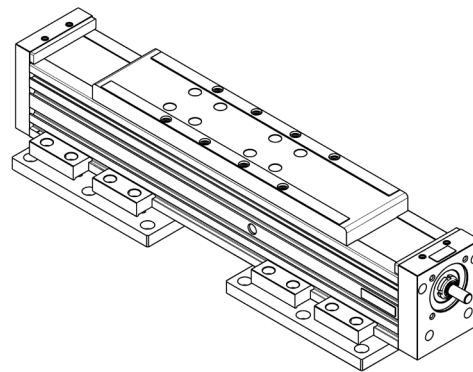
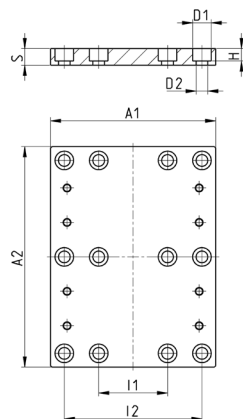

Mod.	Size	A1	A2	$\varnothing D1$	$\varnothing D2$	H	I1	I2	S	Weight (g)
X-P50	50	95	140	9	5,5	6	45	80	8	275
X-P65	65	120	140	10,5	6,5	7	50	100	10	430
X-P80	80	120	160	13,5	8,5	9	50	100	12	570

5E/5V connection flange

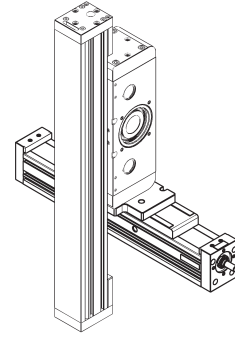
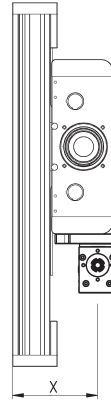
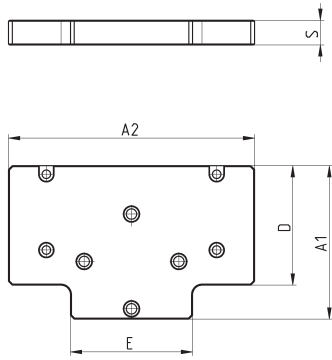

Mod.	Size	X	A1	A2	E	D	S	Weight (g)
YZ-65-5V50	65	124,5	99,5	140	64,5	76,5	13	445
YZ-65-5V65	65	142	101,5	140	84,5	76,5	13	460
YZ-80-5V50	80	133,5	118	190	64,5	78	13	635
YZ-80-5V65	80	150,5	118	190	84,5	78	15	770
YZ-80-5V80	80	170,5	120	190	99,5	78	15	825

Centering ring



Supply includes:
2 steel centering rings

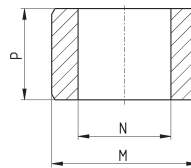
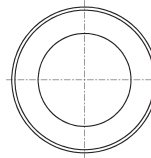

Mod.	M (h8)	N	P
TR-CG-04	Ø4	Ø2,6	2,5
TR-CG-05	Ø5	Ø3,1	3
TR-CG-06	Ø6	Ø4,1	4
TR-CG-08	Ø8	Ø5,1	5
TR-CG-10	Ø10	Ø6,1	6
TR-CG-12	Ø12	Ø8,1	6

Kit for axial connection Mod. AM



Supplied with flexible coupling

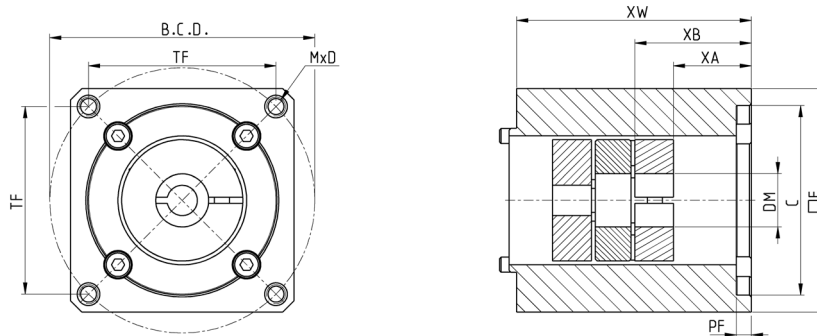

Mod.	Size	Protection class	\varnothing_C	\varnothing_{DM}	B.C.D.	TF	MxD	PF	F	XA	XB	XW	Nominal torque (Nm) ^(A)	Max torque (Nm) ^(B)	J [kg mm ²]	Weight (g)	η
AM-5E-50-0100	50	IP 40	30	8	45	-	M3x8	6,5	49	16	25	56	9	18	2	310	0,78
AM-5E-50-0024	50	IP 40	38,1	8	-	47,1	M4x10	3	59	12	20,5	52	9	18	2	440	0,78
AM-5E-65-0400	65	IP 40	50	14	70	-	M5x7,5	4	59	20	31	62	12,5	25	3	480	0,78
AM-5E-65-0024	65	IP 40	38,1	8	-	47,1	M4x10	4	59	12	20,5	50	9	18	2	430	0,78
AM-5E-80-0750	80	IP 40	70	19	90	-	M6x11	4	79	23	40	71,5	17	34	10	1040	0,78
AM-5E-80-0024	80	IP 40	38,1	8	-	47,1	M4x7,5	4	59	9,5	20,5	51,5	12,5	25	3	400	0,78

^(A) Continuously applicable torque, under ideal mounting and operating conditions. For further details, please contact service@camozzi.com

^(B) Torque applicable for short intervals, under ideal mounting and operating conditions. For further details, please contact service@camozzi.com

Kit for parallel connection Mod. PM

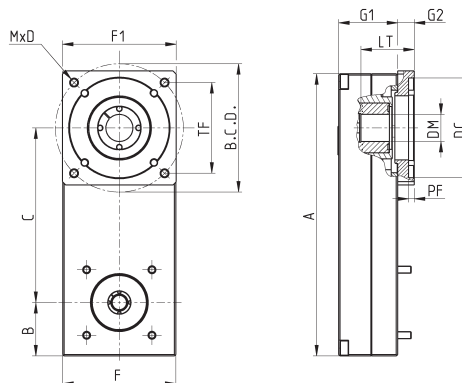
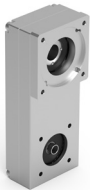

Mod.	Size	Protection class	\varnothing_{DC}	\varnothing_{DM}	LT	B.C.D.	TF	MxD	PF	F	F1	A	B	C	G1	G2	J [kg mm ²]	Weight (g)	η
PM-5E-50-0100	50	IP 40	30	8	20	45	-	M3x8	6	49,5	-	122,5	24,8	72,5	37	-	42,94	490	0,62
PM-5E-50-0024	50	IP 40	38,1	8	22,5	-	47,1	M4x6	2,5	49,5	60	122,5	24,8	72,5	37	6,7	42,94	530	0,62
PM-5E-65-0400	65	IP 40	50	14	26,5	70	-	M5x10	4	64,5	-	164,5	32	94,5	42	-	175,1	990	0,62
PM-5E-65-0024	65	IP 40	38,1	8	18	-	47,1	M4x10	5	64,5	-	164,5	32	94,5	42	-	179,3	1000	0,62
PM-5E-80-0750	80	IP 40	70	19	37,5	90	-	M6x10	4	79,5	80	198	37,5	122,5	41,5	11,7	286,4	1460	0,62
PM-5E-80-0400	80	IP 40	50	14	27	70	-	M5x10	4	79,5	-	198	37,5	120	41,5	-	171,2	1160	0,62
PM-5E-80-0024	80	IP 40	38,1	8	18	-	47,1	M4x10	4	79,5	-	198	37,5	120	41,5	-	175,4	1180	0,62

Transmission performance - PM

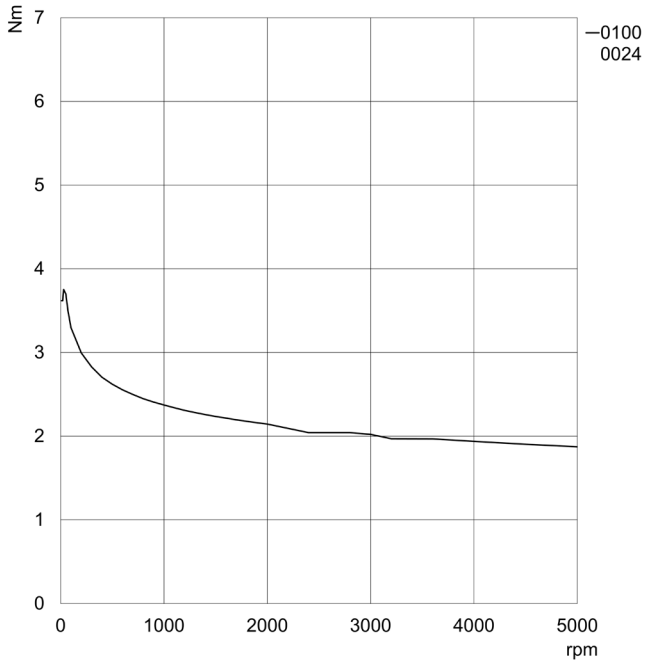

Size 050

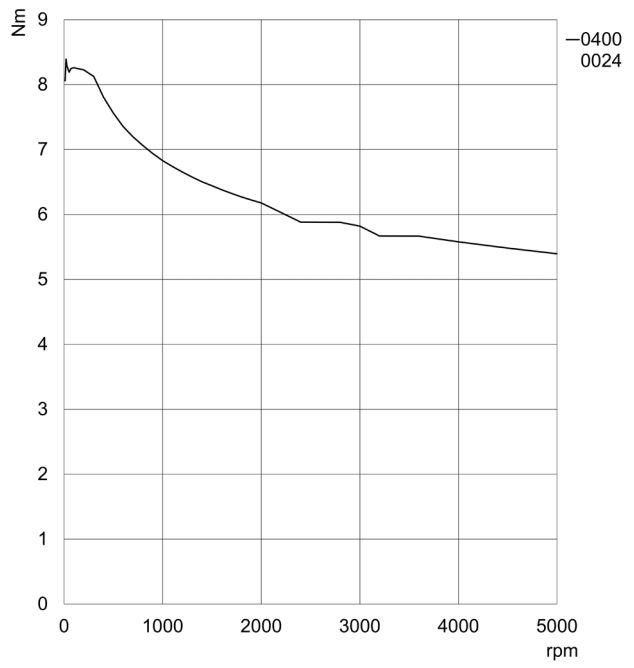

Size 065

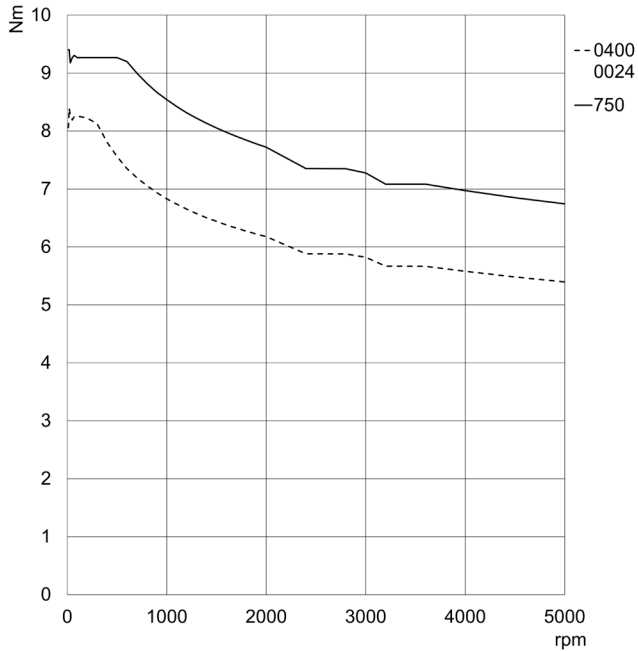

Size 080

Slot nut for sensor

Material: steel

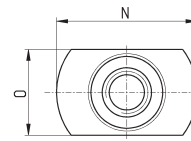
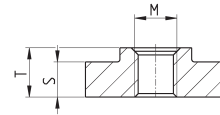
Supplied with:
2x nuts

Mod.	Size	M	N	O	S	T
PCV-5E-CS-M3	50 - 65 - 80	M3	10,3	6,1	2,5	3,5
PCV-5E-CS-M4	50 - 65 - 80	M4	10,3	6,1	2,5	3,5

Slot nut 6 - rectangular type

Material: steel

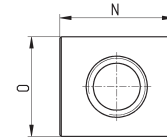
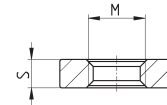
Supplied with:
2x nuts

Mod.	Size	M	N	O	S
PCV-5E-C6-M4Q	50 - 65	M4	8	7	2

Slot nut 6 for front insertion

Material: steel

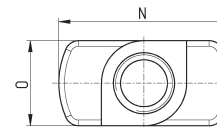
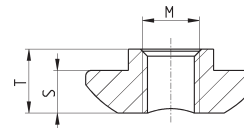
Supplied with:
2x nuts

Mod.	Size	M	N	O	S	T
PCV-5E-C6-M4R	50 - 65	M4	12	6	3	4,5

Slot nut 8 with flexible flap

Material: steel

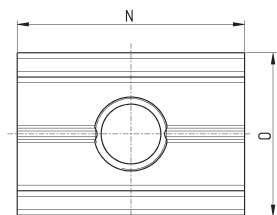
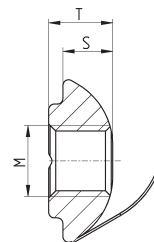
Supplied with:
2x nuts

Mod.	Size	M	N	O	S	T
PCV-5E-C8-M5	80	M5	16	11,5	3,5	4,5
PCV-5E-C8-M6	80	M6	16	11,5	3,5	4,5