

# Compact electromechanical cylinders Series 3E



Sizes 20, 32



- » Flexibility
- » Ease of use
- » Reduced commissioning times
- » Increased machine efficiency and productivity

Series 3E cylinders are electric rod actuators that combine a screw and motor to generate accurate linear motion. These are an alternative to pneumatic cylinders but possessing all the benefits of electric actuators in terms of speed, ease of parameter setting and flexibility in handling different load sizes and formats. Their compact design ensures easy integration with the machine, without affecting performance. Robust and quick, these actuators are ideal for multi-position applications and can be used with external proximity switches for homing operations or allowing extra-stroke readings to be performed.

Moreover, Series 3E can be supplied with the motor already assembled, to further reduce commissioning and wiring time. Series 3E electromechanical cylinders are the ideal solution for industrial applications that require rapid format changeovers or numerous production cycles. Their precision, reliability and flexibility, make these cylinders ideal for use in assembly lines, packaging systems or for material handling.

## GENERAL DATA

Construction	electromechanical cylinder with recirculating ball screw
Design	profile with thread rolling screws based on the ISO 15552 standard
Operation	multi-position actuator with high precision linear movement
Sizes	20, 32
Strokes (min - max)	100 ÷ 500 mm
Anti-rotation function	with anti-friction pads in technopolymer
Mounting	front flange, foot mounts, clamps or front / rear / swivel trunnion
Mounting motor	in line and parallel
Operating temperature	0°C ÷ 50°C
Storage temperature	-20°C ÷ 80°C
Protection class	IP40
Lubrication	Not necessary. A pre-lubrication is performed on the cylinder.
Repeatability	<± 0,02
Duty cycle	100% (if supplied with motor already assembled, the duty cycle depends on the motor selected)
Max rotation play	± 0,4°
Use with external sensors	slots on four sides for sensors model CSD

**CODING EXAMPLE**

<b>3E</b>	<b>020</b>	<b>BS</b>	<b>0100</b>	<b>P10</b>	<b>M</b>	
-----------	------------	-----------	-------------	------------	----------	--

<b>3E</b>	SERIES
<b>020</b>	SIZE 020 = 20 032 = 32
<b>BS</b>	TRANSMISSION BS = recirculating ball screw
<b>0100</b>	STROKE See table of mechanical characteristics
<b>P10</b>	SCREW PITCH P03 = 3 mm P10 = 10 mm
<b>M</b>	CONSTRUCTION M = male F = female
	EXTENDED ROD (___) = rod extended with ___ mm

**MECHANICAL CHARACTERISTICS**

MECHANICAL CHARACTERISTICS					
		Size 20	Size 20	Size 32	Size 32
Pitch "P"	[mm]	3	10	3	10
Dynamic load coefficient "C"	[N]	2100	1875	2800	2500
Average load <sup>(A)</sup>	[N]	177	236	236	315
Max torque applicable to screw's shaft	[Nm]	0,42	1,41	0,53	1,77
Max force applicable*	[N]	800	800	1000	1000
Max linear speed cylinder*	[m/s]	0,4	1,3	0,4	1,3
Maximum rotation speed of the cylinder shaft	[rpm]	8000	8000	8000	8000
Max acceleration of cylinder	[m/s <sup>2</sup> ]	25	25	25	25
Min Stroke	[mm]	10	25	10	25
Max Stroke	[mm]	300	300	500	500

<sup>(A)</sup> Value refers to a covered distance of 5000 Km (see the diagrams "Life of the cylinder according to the average axial force applied").

\* This parameter varies as the stroke varies (see the diagrams "Maximum speed of the cylinder according to its stroke").

## SERIES 3E MATERIALS

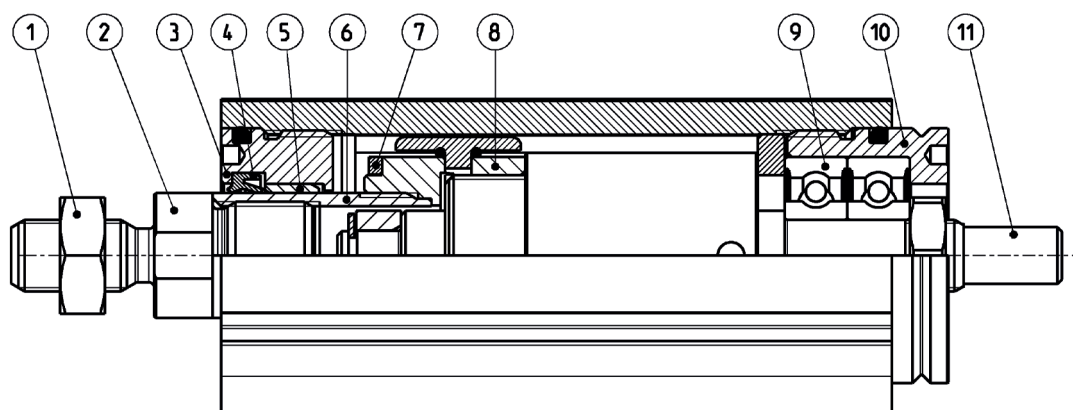

LIST OF COMPONENTS	
PARTS	MATERIALS
1. Rod nut	Zinc-plated steel
2. Front coupling piece	Stainless steel
3. Front cap	Anodized aluminium alloy
4. Rod seal	PU
5. Bushing	Technopolymer
6. Rod	Stainless steel
7. Magnet	Plastoferrite
8. Guiding element BS screw	Aluminium alloy
9. Bearing	Steel
10. Rear cap	Anodized aluminium alloy
11. BS ball screw	Steel

**ACCESSORIES FOR SERIES 3E CYLINDERS**



Piston rod socket joint  
Mod. GY



Piston rod lock nut  
Mod. U



Clevis pin Mod. S

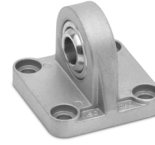

Rear trunnion ball-joint  
Mod. R

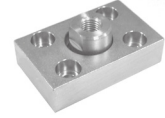

Coupling piece  
Mod. GKF



Swivel ball joint Mod. GA



90° male trunnion  
Mod. ZC



Swivel Combination  
Mod. C+L+S

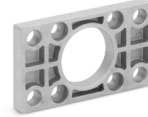

Front flange  
Mod. D-E



Self aligning rod  
Mod. GK



Foot mount Mod. B-6E



Rear female trunnion  
Mod. C and C-H

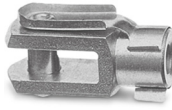

Rod fork end Mod. G



Rear trunnion male  
Mod. L

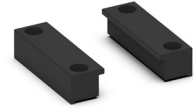

Side clamping bracket  
Mod. BG



Kit for axial connection  
Mod. AM

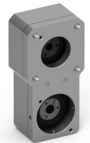

Kit for parallel connection  
Mod. PM

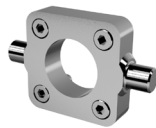

Front spot faced trunnion  
Mod. FN



Counter bracket for  
trunnion Mod. BF

COMPACT ELECTROMECHANICAL CYLINDERS SERIES 3E

## HOW TO CALCULATE THE LIFE OF THE CYLINDER

To perform a correct dimensioning of the Series 3E cylinder, you need to consider some facts.

Among these, the most important are:

- Dynamics of the system
- Operation and pause cyclicity
- Work environment
- General performance requirements: repeatability, accuracy, precision, etc.

### CALCULATE THE LIFE IN ROTATIONS

where:

$L_r$  = Life of the cylinder in number of rotations of the BS ball screw

$C$  = Dynamic load coefficient of the cylinder [N]

$F_m$  = Average axial force applied [N]

$f_w$  = Safety coefficient according to the working conditions (see table below)

$$L_r = \left( \frac{C}{F_m \cdot f_w} \right)^3 \cdot 10^6$$

### CALCULATION OF LIFE IN km

where:

$L_{km}$  = Life of the cylinder in km [km]

$p$  = pitch of the BS ball screw [mm]

$$L_{km} = \frac{L_r \cdot p}{10^6}$$

### CALCULATION OF THE LIFE IN HOURS

where:

$L_h$  = Life of the cylinder in hours

$n_m$  = average number of revolutions of the RDS ball screw [rpm]

$$L_h = \frac{L_r}{n_m \cdot 60}$$

APPLICATION	ACCELERATION [ m/s <sup>2</sup> ]	SPEED [ m/s ]	DUTY CYCLE	$f_w$ COEFFICIENT
light	< 5,0	< 0,5	< 35%	1,0 ÷ 1,25
normal	5,0 ÷ 15,0	0,5 ÷ 1,0	35% ÷ 65%	1,25 ÷ 1,5
heavy	> 15,0	> 1,0	> 65%	1,5 ÷ 3,0

## ANALYSIS OF THE DUTY CYCLE AND OF SYSTEM PAUSES

The analysis of the duty cycle and of the pauses of the system is essential to calculate the average  $F_m$  axial loads and the number of average revolutions  $n_m$  that act on the cylinder. Normally, the duty cycle is composed by phases and for each single phase, we can have an acceleration, constant speed or deceleration.

$F_m$  = CALCULATION OF THE AVERAGE AXIAL FORCE

$n_m$  = CALCULATION OF THE AVERAGE NUMBER OF REVOLUTIONS

The table shown below reports the values of acceleration, speed and deceleration for each phase.

$$F_m = \sqrt[3]{\frac{(F_{a1}^3 \cdot n_{a1} \cdot t_{a1}) + (F_{vc1}^3 \cdot n_{vc1} \cdot t_{vc1}) + (F_{d1}^3 \cdot n_{d1} \cdot t_{d1}) + \dots + (F_{an}^3 \cdot n_{an} \cdot t_{an}) + (F_{vcn}^3 \cdot n_{vcn} \cdot t_{vcn}) + (F_{dn}^3 \cdot n_{dn} \cdot t_{dn})}{(n_{a1} \cdot t_{a1}) + (n_{vc1} \cdot t_{vc1}) + (n_{d1} \cdot t_{d1}) + \dots + (n_{an} \cdot t_{an}) + (n_{vcn} \cdot t_{vcn}) + (n_{dn} \cdot t_{dn})}}$$

$$n_m = \left\{ \frac{(n_{a1} \cdot t_{a1}) + (n_{vc1} \cdot t_{vc1}) + (n_{d1} \cdot t_{d1}) + \dots + (n_{an} \cdot t_{an}) + (n_{vcn} \cdot t_{vcn}) + (n_{dn} \cdot t_{dn})}{t_{a1} + t_{vc1} + t_{d1} + \dots + t_{an} + t_{vcn} + t_{dn}} \right\}$$

		F [N]	n [rpm]	time %
PHASE 1	Acceleration	Fa1	na1	ta1
	Constant speed	Fvc1	nvc1	tvc1
	Deceleration	Fd1	nd1	td1
PHASE 2	Acceleration	Fa2	na2	ta2
	Constant speed	Fvc2	nvc2	tvc2
	Deceleration	Fd2	nd2	td2
PHASE "n -1"	Acceleration	Fan-1	nan-1	tan-1
	Constant speed	Fvcn-1	nvcn-1	tvcn-1
	Deceleration	Fdn-1	ndn-1	tdn-1
PHASE "n"	Acceleration	Fan	nan-1	tan-1
	Constant speed	Fvcn	nvcn-1	tvcn-1
	Deceleration	Fdn	ndn-1	tdn-1
<b>TOTAL</b>				<b>100%</b>

## APPLICATION EXAMPLE

Phase 1	$F_{a1} = 142 \text{ N};$ $n_{a1} = 630 \text{ rpm};$ $t_{a1} = 0,7 \text{ %};$	$F_{vc1} = 98 \text{ N};$ $n_{vc1} = 1260 \text{ rpm};$ $t_{vc1} = 12,9 \text{ %};$	$F_{d1} = 54 \text{ N};$ $n_{d1} = 630 \text{ rpm};$ $t_{d1} = 0,7 \text{ %};$
Phase 2	$F_{a2} = 616 \text{ N};$ $n_{a2} = 450 \text{ rpm};$ $t_{a2} = 4,8 \text{ %};$	$F_{vc2} = 589 \text{ N};$ $n_{vc2} = 900 \text{ rpm};$ $t_{vc2} = 33,3 \text{ %};$	$F_{d2} = 562 \text{ N};$ $n_{d2} = 450 \text{ rpm};$ $t_{d2} = 4,8 \text{ %};$
Phase 3	$F_{a3} = 997 \text{ N};$ $n_{a3} = 240 \text{ rpm};$ $t_{a3} = 7,1 \text{ %};$	$F_{vc3} = 981 \text{ N};$ $n_{vc3} = 480 \text{ rpm};$ $t_{vc3} = 28,6 \text{ %};$	$F_{d3} = 965 \text{ N};$ $n_{d3} = 240 \text{ rpm};$ $t_{d3} = 7,1 \text{ %};$

in this way it is possible to determine:

$$K_1 = (F_{a1}^3 \cdot n_{a1} \cdot t_{a1}) + (F_{vc1}^3 \cdot n_{vc1} \cdot t_{vc1}) + (F_{d1}^3 \cdot n_{d1} \cdot t_{d1}) \quad n_1 = (n_{a1} \cdot t_{a1}) + (n_{vc1} \cdot t_{vc1}) + (n_{d1} \cdot t_{d1}) \quad T_1 = t_{a1} + t_{vc1} + t_{d1}$$

$$K_2 = (F_{a2}^3 \cdot n_{a2} \cdot t_{a2}) + (F_{vc2}^3 \cdot n_{vc2} \cdot t_{vc2}) + (F_{d2}^3 \cdot n_{d2} \cdot t_{d2}) \quad n_2 = (n_{a2} \cdot t_{a2}) + (n_{vc2} \cdot t_{vc2}) + (n_{d2} \cdot t_{d2}) \quad T_2 = t_{a2} + t_{vc2} + t_{d2}$$

$$K_3 = (F_{a3}^3 \cdot n_{a3} \cdot t_{a3}) + (F_{vc3}^3 \cdot n_{vc3} \cdot t_{vc3}) + (F_{d3}^3 \cdot n_{d3} \cdot t_{d3}) \quad n_3 = (n_{a3} \cdot t_{a3}) + (n_{vc3} \cdot t_{vc3}) + (n_{d3} \cdot t_{d3}) \quad T_3 = t_{a3} + t_{vc3} + t_{d3}$$

Concluding, we know that:

$$F_m = \sqrt[3]{\frac{(K_1 + K_2 + K_3)}{(n_1 + n_2 + n_3)}} = 596,64 \text{ N}$$

$$n_m = \frac{n_1 + n_2 + n_3}{T_1 + T_2 + T_3} = 685,7 \text{ rpm}$$

		F [N]	n [rpm]	time %
PHASE 1	Acceleration	142	630	0,7
	Constant speed	98	1260	12,9
	Deceleration	54	630	0,7
PHASE 2	Acceleration	616	450	4,8
	Constant speed	589	900	33,3
	Deceleration	562	450	4,8
PHASE 3	Acceleration	997	240	7,1
	Constant speed	981	480	28,6
	Deceleration	965	240	7,1
<b>TOTAL</b>				<b>100,0</b>

## HOW TO CALCULATE THE DRIVING TORQUE [Nm]

$F_A$  = Total force acting from outside [N]

$p$  = Pitch of the ball screw [mm]

$\eta$  = Performance

$C_{M1}$  = Driving torque due to external agents [Nm]

$$C_{TOT} = C_{M1} + C_{M2} + C_{M3}$$

$$C_{M1} = \frac{F_A \cdot p}{2\pi \cdot 1000} \cdot \frac{1}{\eta}$$

$J_{TOT}$  = Moment of inertia of rotating components [kg·m<sup>2</sup>]

$J_F$  = Moment of inertia of fixed-length rotating components [kg·m<sup>2</sup>]

$J_V$  = Moment of inertia of variable-length rotating components [kg·m<sup>2</sup>]

$K_V$  = Coefficient of inertia of variable-length rotating components [kg·mm<sup>2</sup>/mm]

$C$  = Rod stroke [mm]

$\dot{\omega}$  = Angular acceleration [rad/s<sup>2</sup>]

$a$  = Linear acceleration of the ball screw [m/s<sup>2</sup>]

$C_{M2}$  = Driving torque due to rotating components [Nm]

$$J_{TOT} = (J_F + J_V) \cdot 10^{-6}$$

$$J_V = K_V \cdot C$$

$$\dot{\omega} = \frac{a \cdot 2\pi \cdot 1000}{p}$$

$$C_{M2} = J_{TOT} \cdot \dot{\omega} \cdot \frac{1}{\eta}$$

$F_{TT}$  = Force needed to move sliding components [N]

$F_{TF}$  = Force needed to move fixed-length sliding components [N]

$F_{TV}$  = Force needed to move variable-length sliding components [N]

$m_{c1}$  = Mass of the fixed-length sliding components [kg]

$K_{TV}$  = Mass coefficient of variable-length sliding components [kg/mm]

$C_{M3}$  = Driving torque due to sliding components [Nm]

$$F_{TT} = F_{TF} + F_{TV}$$

$$F_{TF} = m_{c1} \cdot a$$

$$F_{TV} = K_{TV} \cdot C \cdot a$$

$$C_{M3} = \frac{F_{TT} \cdot p}{2\pi \cdot 1000} \cdot \frac{1}{\eta}$$

Values of masses and fixed and rotating inertia moments of 3E components				
Size	$J_F$ [ kg·mm <sup>2</sup> ]	$K_V$ [ kg·mm <sup>2</sup> /mm ]	$m_{c1}$ [ kg ]	$K_V$ [ kg/m ]
20	2,1	6,13	0,12	0,46
32	2,1	6,13	0,13	0,46

**Life of the cylinder according to the average axial force applied (environmental T and standard conditions of use)**

COMPACT ELECTROMECHANICAL CYLINDERS SERIES 3E

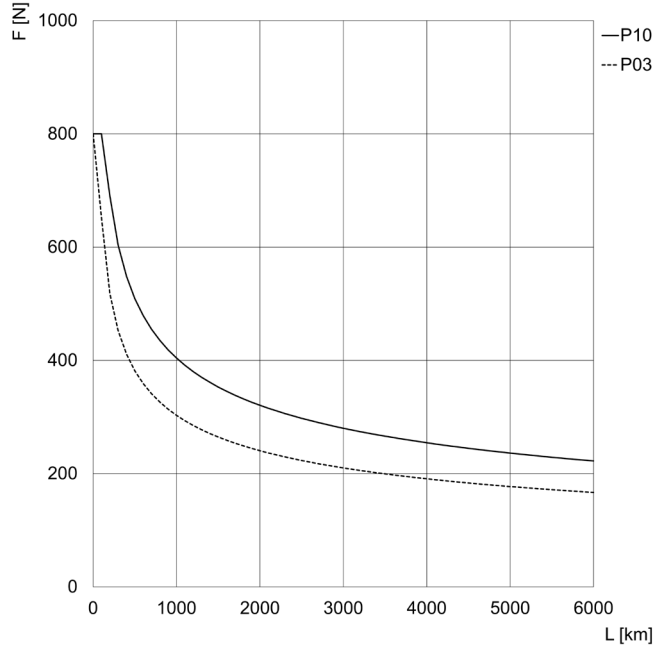

Size 20

F = Axial Force [N]  
L = life [km]  
Curves calculated with  $f_w = 1$

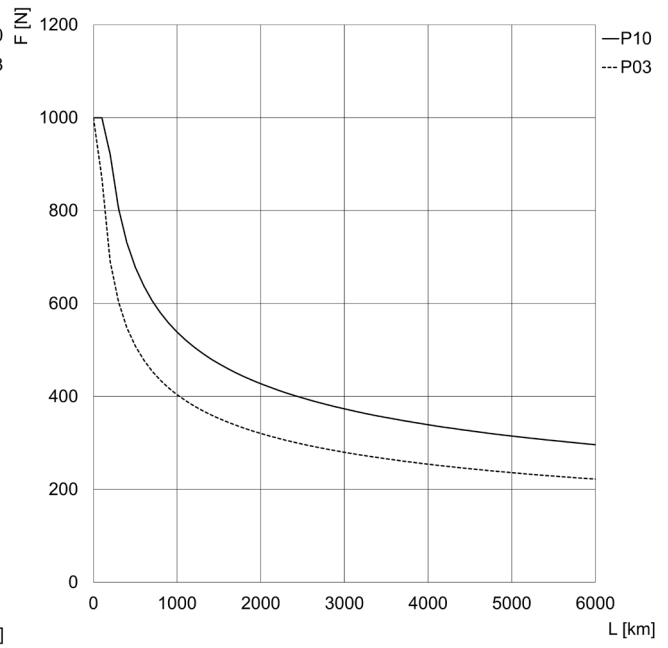

Size 32

F = Axial Force [N]  
L = life [km]  
Curves calculated with  $f_w = 1$



### Maximum speed of the cylinder according to its stroke

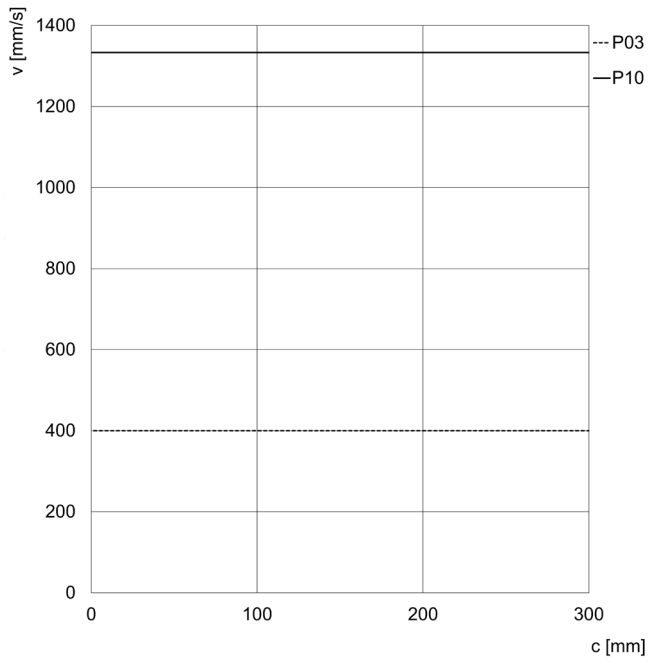

Size 20

$v$  = speed [m/s]  
 $c$  = stroke [mm]

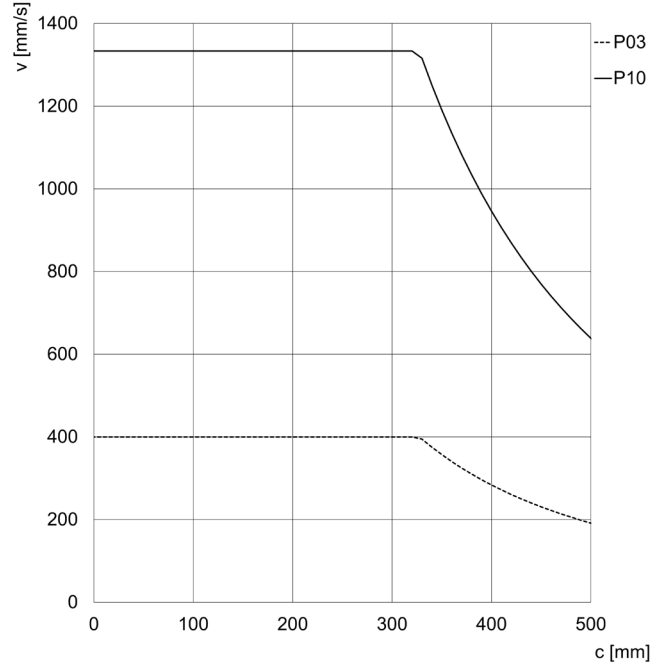

Size 32

$v$  = speed [m/s]  
 $c$  = stroke [mm]

**Maximum force of the cylinder according to its stroke**

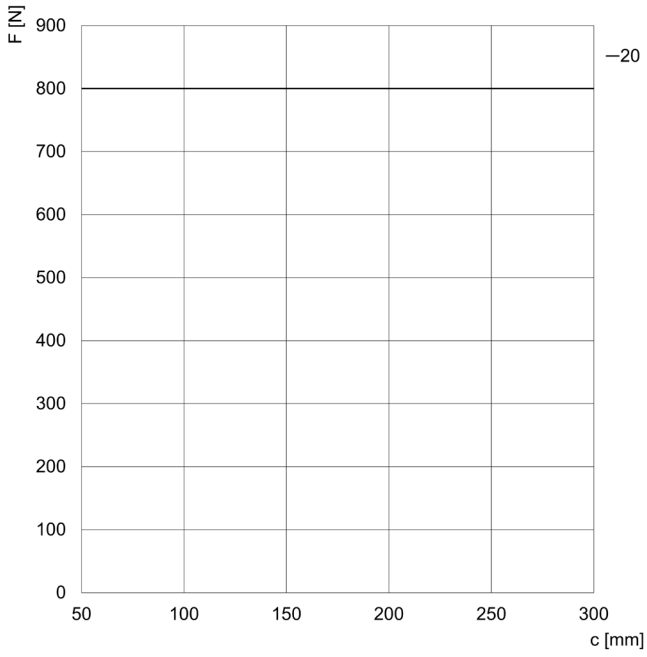

Size 20

F = static axial Force [N]  
c = stroke [mm]

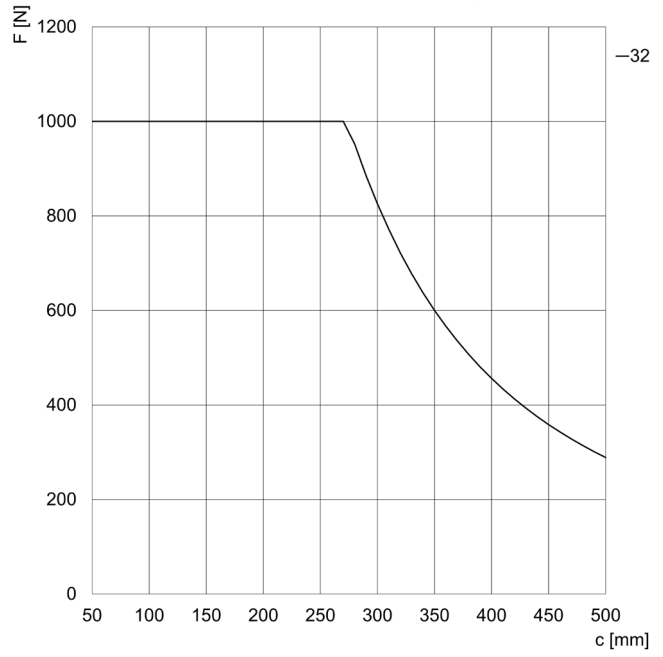

Size 32

F = static axial Force [N]  
c = stroke [mm]

For longer strokes than the standard ones or for extended rods, please contact Camozzi.

## Series 3E cylinders



+ = add the stroke  
 \* Dimension not in compliance with ISO 15552 standard

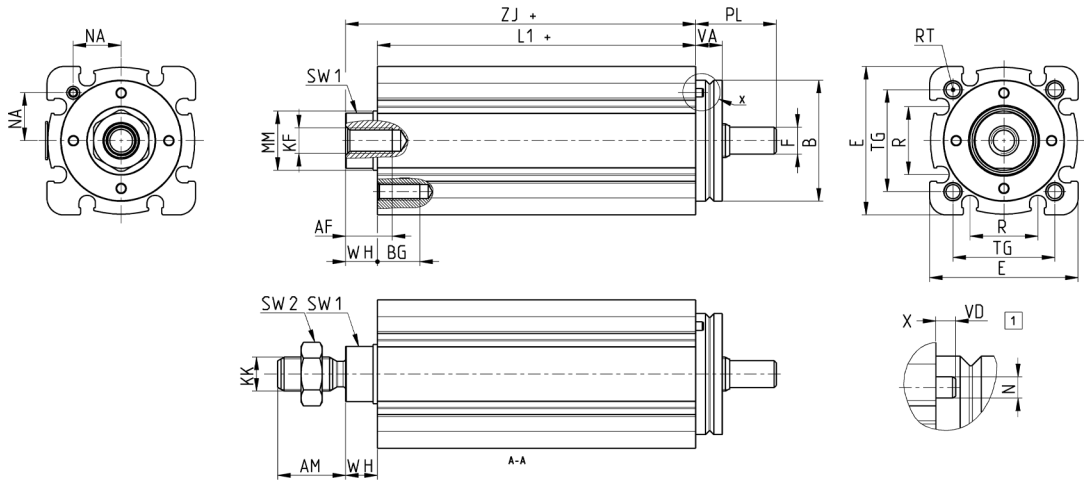

Size	AM	AF	$\varnothing_B^{(h8)}$	BG	E	$\varnothing_F^{(h8)}$	KF	KK	L1+	$\varnothing_{MM}$	R	RT	PL	SW1	SW2	TG	VA	VD	$\varnothing_N$	NA	WH	ZI+	weight stroke 0 [g]	weight stroke [kg/m]
20	16	11	28,5	10	35	5	M6	M8x1,25	75	14	16	M4	19	13	13	24	6,5	2	2,2	11,3	7,5	82,5	326	2,57
32	19	13	34	10	42	5	M8	M10x1,25	75	14	19	M5	19	13	17	32,5	5,5	2	2,2	13,5	7,5	82,5	430	3,64

## Kit for axial connection Mod. AM

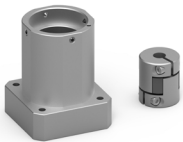

The supply includes:  
 1x housing  
 1x flexible coupling  
 4x nuts  
 4x motor connection screws

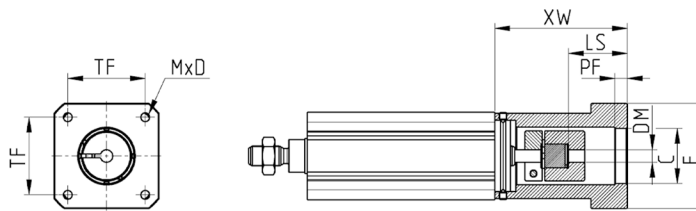

Mod.	Size	Motor	Protection	$\varnothing_C$	$\varnothing_{DM}$	TF	MxD	PF	F	LS	XW	Nominal torque (Nm) <sup>(A)</sup>	Max torque (Nm) <sup>(B)</sup>	J[kgmm <sup>2</sup> ]	Weight [g]	$\eta$
AM-3E-20-0017	20	MTS-17-...	IP40	22	5	31	$\varnothing 3,5 \times 14,5$	5	42	24	53	5	10	0,85	127	0,78
AM-3E-32-0023	32	MTS-23-...	IP40	38,1	6,35	47,14	M4x15	9	56,4	20	49	5	10	0,85	152	0,78
AM-3E-32-0024	32	MTS-24-...	IP40	38,1	8	47,14	M4x15	9	56,4	20	49	5	10	0,85	152	0,78
AM-3E-32-0100	32	MTB-010-...	IP40	30	8	31,8	M3x9	5	41,5	25	54	5	10	0,85	144	0,78

<sup>(A)</sup> Continuously applicable torque, under ideal mounting and operating conditions. For further details, please contact [service@camozzi.com](mailto:service@camozzi.com)

<sup>(B)</sup> Torque applicable for short intervals, under ideal mounting and operating conditions. For further details, please contact [service@camozzi.com](mailto:service@camozzi.com)

**Kit for parallel connection Mod. PM**



- Supplied with:  
 1x front cover  
 1x rear cover  
 2x pulleys  
 2x locking sets  
 1x toothed belt  
 3x nuts  
 4x rear cover screws  
 2-4x cover fixing screws  
 2x cylindrical pins  
 4x motor fixing screws

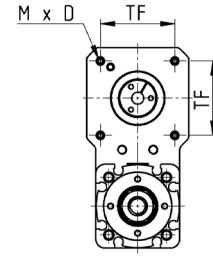
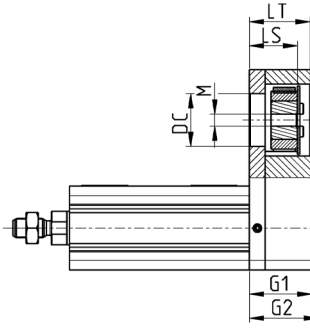
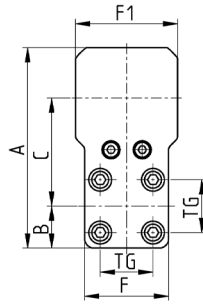

COMPACT ELECTROMECHANICAL CYLINDERS SERIES 3E

Mod.	Size	Motor	Protection	A	B	C	F	F1	TG	G1	G2	DC	M	LS	LT	TF	MxD	J[kgmm <sup>2</sup> ]	Weight [g]	η
PM-3E-20-0017	20	MTS-17-...	IP40	83,5	17,5	45	35	42,5	22	26	29	22	5	20	25	31	M3x4,5	3,96	218	0,62
PM-3E-32-0023	32	MTS-23-...	IP40	116,5	21	67,5	42	56,5	32,5	28	31	38,1	6,35	19	26,5	47,14	M4x6	5,84	390	0,62
PM-3E-32-0024	32	MTS-24-...	IP40	116,5	21	67,5	42	56,5	32,5	28	31	38,1	8	19	26,5	47,14	M4x6	5,84	390	0,62
PM-3E-32-0100	32	MTB-010-...	IP40	87	21	45	42	42	32,5	28	31	30	8	19	26,5	31,82	M3x6	5,82	245	0,62

**TRANSMISSIBLE POWER KIT PM**

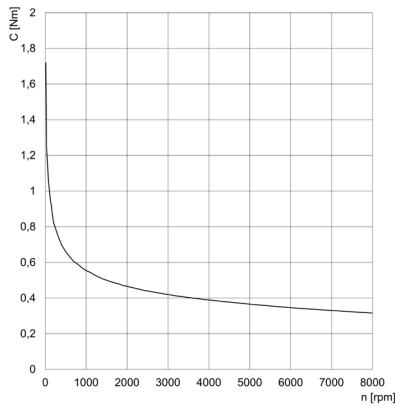

PM-3E 20...  
 C = Torque [Nm]  
 n = number of revolutions per minute

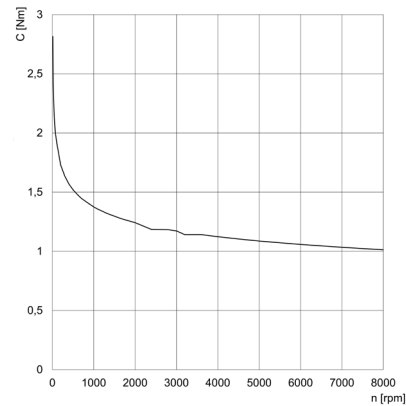

PM-3E 32...  
 C = Torque [Nm]  
 n = number of revolutions per minute

The curves refer to a duty cycle of 70%

## Foot bracket Mod. B-3E-AM



Material: zinc-plated steel

Supplied with:  
2x foot brackets  
4x screws

+ = add the stroke

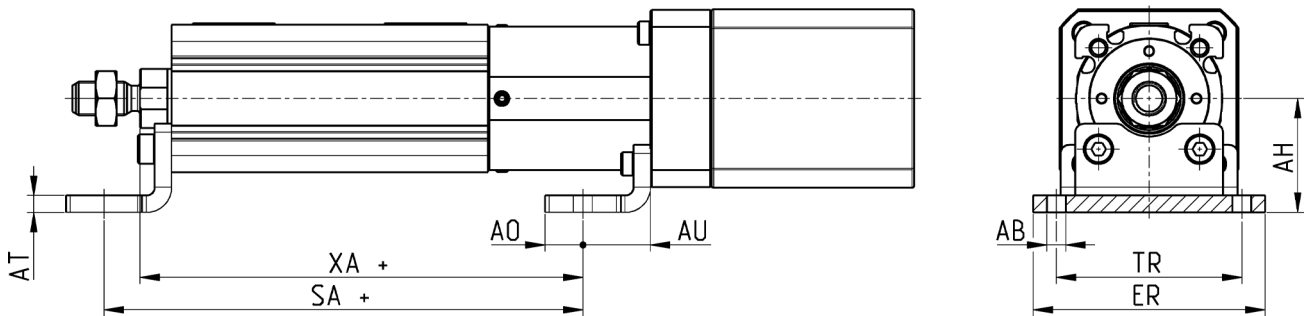

Mod.	Size	Compatible with	SA	XA	AH	TR	AT	AU	AO	AB	ER
B-3E-20-AM	20	AM-3E-20-0017	113,5	105	28	44	4	16	9	4,5	55
B-3E-32-AM-1	32	AM-3E-32-0023 / AM-3E-32-0024	109	100,5	36	52	4	16	9	4,5	62
B-3E-32-AM-2	32	AM-3E-32-0100	99	90,5	36	52	4	16	9	4,5	62

**Foot bracket Mod. B-3E-PM**

Material: zinc-plated steel

Supplied with:  
2x foot brackets  
4x screws

+ = add the stroke



COMPACT ELECTROMECHANICAL CYLINDERS SERIES 3E

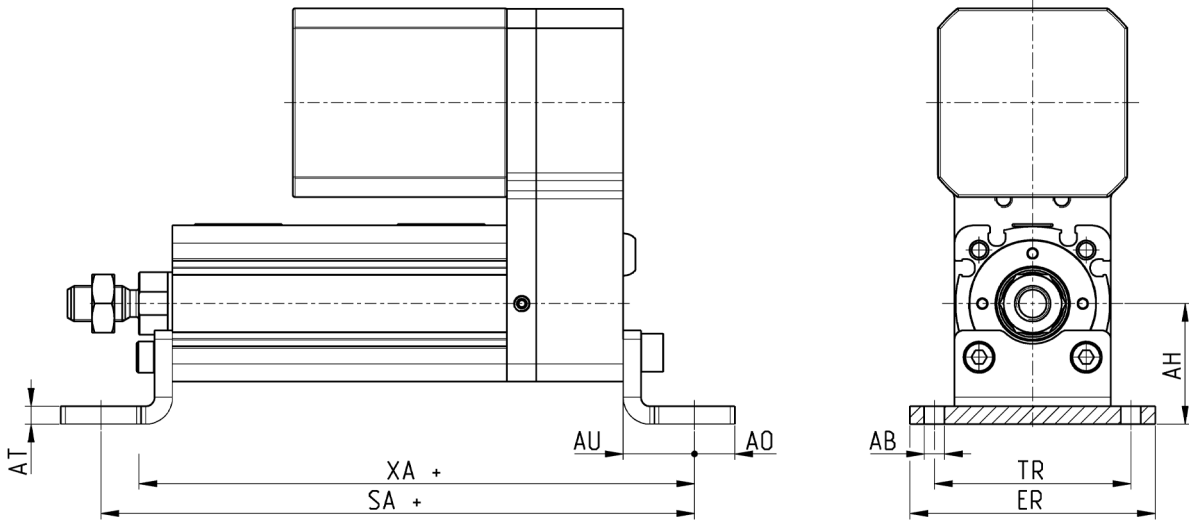

Mod.	Size	Compatible with	SA	XA	AH	TR	AT	AU	AO	AB	ER
B-3E-20-PM	20	PM-3E-20-0017	133	124,5	28	44	4	16	9	4,5	55
B-3E-32-PM	32	PM-3E-32-0023 / PM-3E-32-0024 / PM-3E-32-0100	135	126,5	36	52	4	16	9	4,5	62

### Front spot faced trunnion Mod. FN

Material: zinc-plated steel

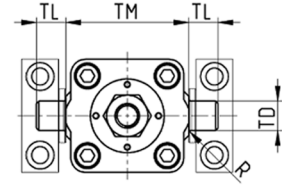
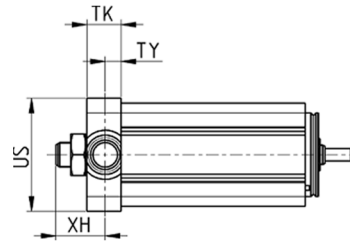
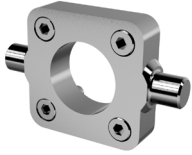

Supplied with:  
1x spot faced trunnion  
4x screws  
4x washers

Mod.	∅	TK	TY	XH	US	TL	TM	∅TD	R
FN-3E-32	32	14	6,5	20	46	12	50	12	1

### Counter bracket for front trunnion Mod. BF

Material: aluminium

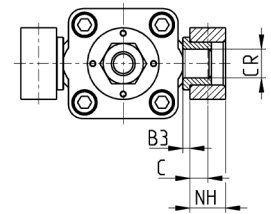
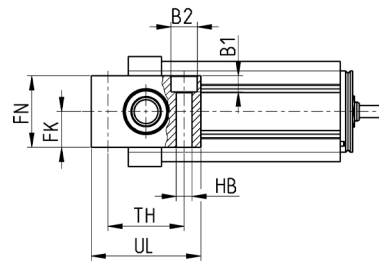

Supplied with:  
2x supports

Mod.	∅	∅CR	NH	C	B3	TH	UL	FK	FN	B1	B2	HB
BF-32	32	12	15	7,5	3	32	46	15	30	6,8	11	6,6

### Front flange Mod. D-E

Material: aluminium

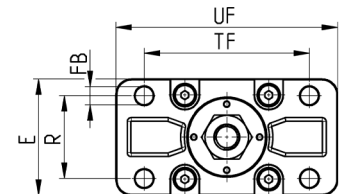
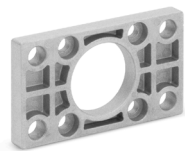

Supplied with:  
1x flange  
4x screws  
4x washers

+ = add the stroke

Mod.	Size	W	MF	TF	R	UF	E	FB
D-E-3E-32	32	16,5	10	64	32	80	45	7

### Side clamping bracket Mod. BG

Material: aluminium

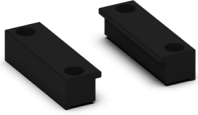

Supplied with:  
2x clamps

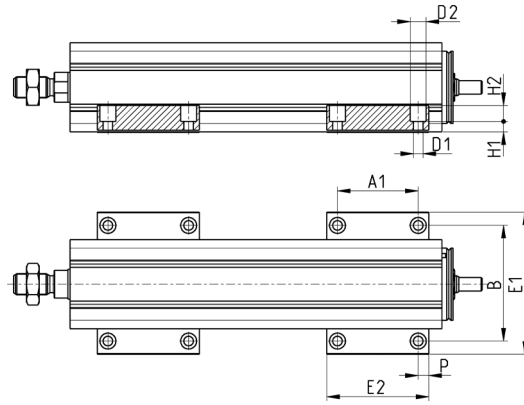

Mod.	Size	E1	E2	P	A1	B	Screw	øD1	øD2	H1	H2	Weight [g]
BG-3E-20	20	60	48	5	38	47,5	M4	4,5	7,5	5	5,5	31
BG-3E-32	32	67	48	5	38	54,5	M4	4,5	7,5	5	7,5	35

### Rear male trunnion Mod. L

Material: aluminium



Supplied with:  
1x male trunnion  
4x screws  
4x washers (only for size 32)

+ = add the stroke

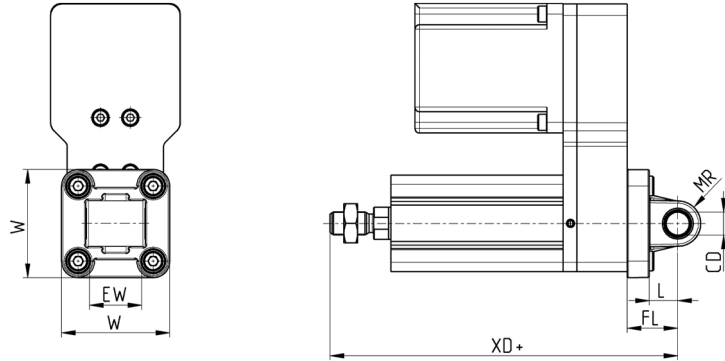

Mod.	Size	øCD	L	FL	XD+	MR	E	EW
L-3E-20	20	8	14	20	151,5	8	34	16
L-3E-32	32	10	13	22	151,5	10	46	26

### Rear female trunnion Mod. C

Material: aluminium



Supplied with:  
1x female trunnion  
4x screws  
4x washers

+ = add the stroke

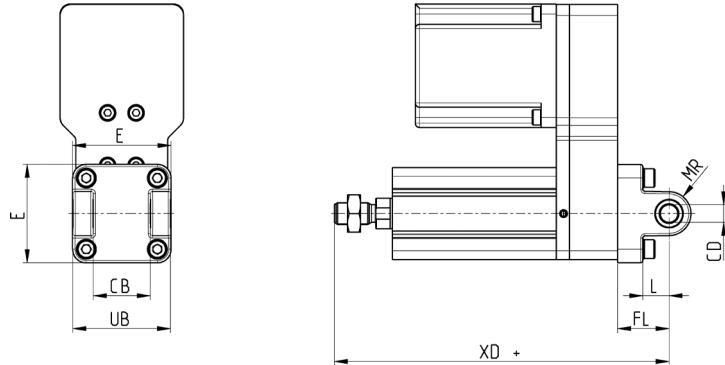

Mod.	Size	øCD	L	FL	XD+	MR	E	CB	UB
C-3E-32	32	10	13	22	212	10	46	26	45



### 90° male trunnion Mod. ZC

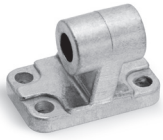

CETOP RP 107P  
Material: aluminium

Supplied with:  
1x male support

+ = add the stroke

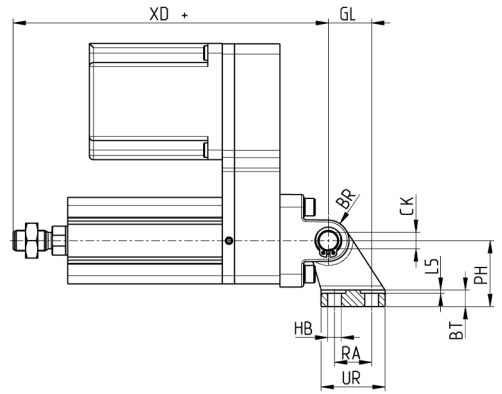
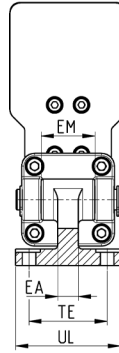

Mod.	Size	$\varnothing_{EB}$	$\varnothing_{CK}$	$\varnothing_{HB}$	XD+	TE	UL	EA	GL	L5	RA	EM	UR	PH	BT	BR
ZC-32	32	11	10	6,6	212	38	51	10	21	1,6	18	26	31	32	8	10

### Trunnion ball-joint Mod. R



Supplied with:  
1x trunnion ball-joint  
4x screws  
4x washers

+ = add the stroke

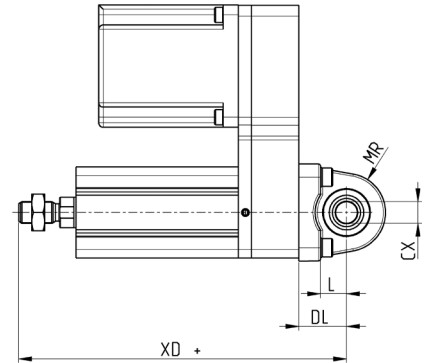
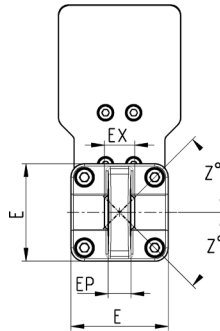

Mod.	Size	$\varnothing_{CX}$	L	DL	XN+	MS	E	EX	EP	Z
R-3E-32	32	10	12	22	212	18	45	14	10,5	4°

### Clevis pin Mod. S



Supplied with:  
1x clevis pin in stainless steel 303  
2x Seeger in steel

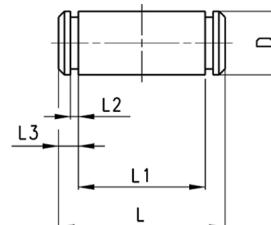

Mod.	Size	$\varnothing_D$	L	L1	L2	L3
S-32	32	10	52	46	1,1	3

### Swivel ball joint Mod. GA



ISO 8139.  
Material: zinc-plated steel

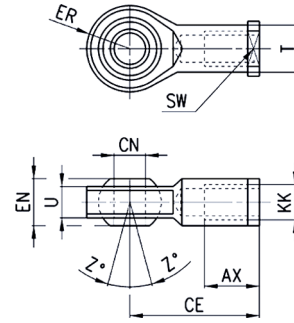

Mod.	Size	$\varnothing$ CN	U	EN	ER	AX	CE	KK	$\varnothing$ T	Z	SW
GA-20	20	8	9	12	12	16	36	M8x1,25	12,5	6,5	14
GA-32	32	10	10,5	14	14	20	43	M10x1,25	15	6,5	17

### Piston rod socket joint Mod. GY



Material: zama and zinc-plated steel

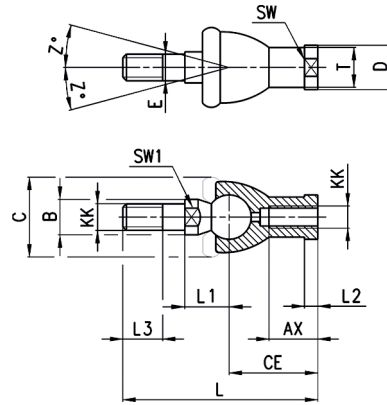

Mod.	Size	KK	L	CE	L2	AX	SW	SW1	L1	L3	$\varnothing$ T	$\varnothing$ D	E	$\varnothing$ B	$\varnothing$ C	Z
GY-20	20	M8x1,25	65	32	5	16	14	10	16	12	12,5	13	6	10	20	15
GY-32	32	M10x1,25	74	35	6,5	18	17	11	19,5	15	15	19	10	14	28	15

### Rod fork end Mod. G

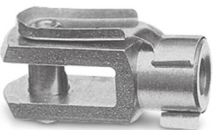

ISO 8140  
Material: zinc-plated steel

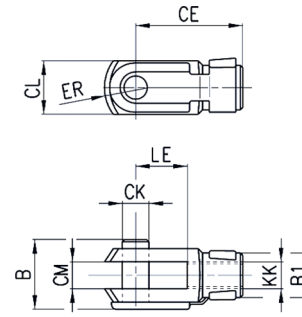

Mod.	Size	$\varnothing$ CK	LE	CM	CL	ER	CE	KK	B	$\varnothing$ B1
G-20	20	8	16	8	16	10	32	M8x1,25	22	14
G-25-32	32	10	20	10	20	12	40	M10x1,25	26	18

## Piston rod lock nut Mod. U

ISO 4035  
Material: zinc-plated steel

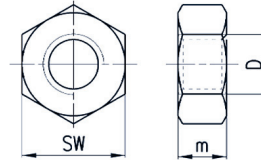

Mod.	Size	D	M	SW
U-20	20	M8x1,25	5	13
U-25-32	32	M10x1,25	6	17

## Self aligning rod Mod. GK

Material: zinc-plated steel

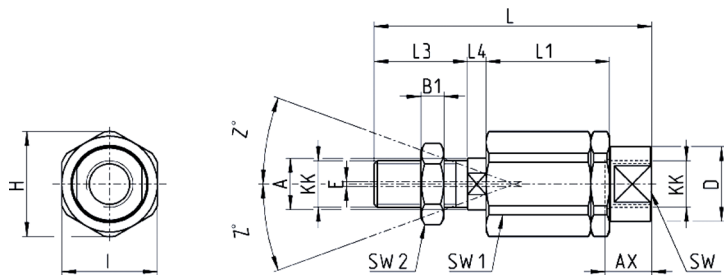

Mod.	Size	KK	L	L1	L3	L4	$\varnothing A$	$\varnothing D$	H	I	SW	SW1	SW2	B1	AX	Z	E
GK-20	20	M8x1,25	57	26	21	5	8	12,5	19	17	11	7	13	4	16	4	2
GK-25-32	32	M10x1,25	71,5	35	20	7,4	14	22	32	30	19	12	17	5	22	4	2

## Coupling piece Mod. GKF

Material: zinc-plated steel

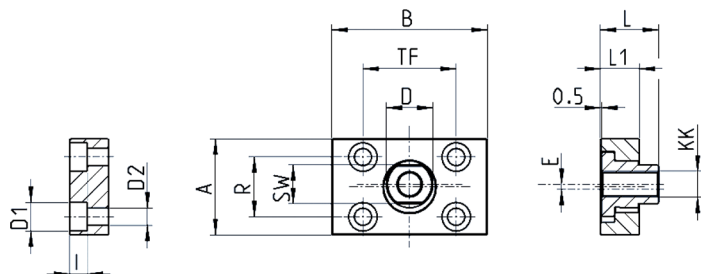

Mod.	Size	KK	A	B	R	TF	L	L1	I	$\varnothing D$	$\varnothing D1$	$\varnothing D2$	SW	E
GKF-20	20	M8x1,25	30	35	20	25	22,5	10	-	14	5,5	-	13	1,5
GKF-25-32	32	M10x1,25	37	60	23	36	22,5	15	6,8	18	11	6,6	15	2

# Cylinder configuration with assembled motor

Cylinder supplied with assembled motor and standard accessories AM and PM.

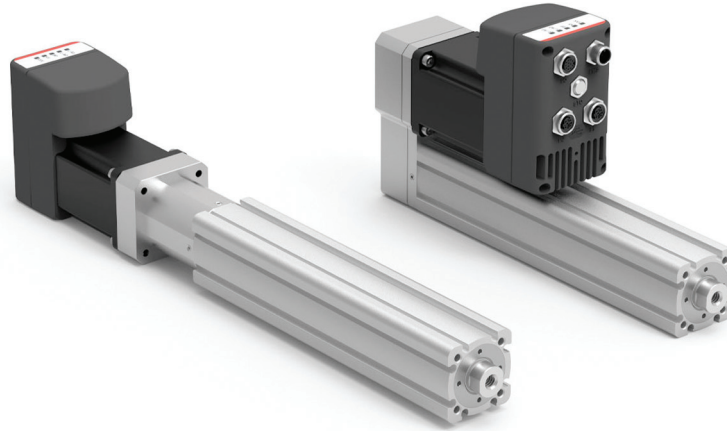

COMPACT ELECTROMECHANICAL CYLINDERS SERIES 3E

## CODING EXAMPLE

<b>3E</b>	<b>020</b>	<b>BS</b>	<b>0100</b>	<b>P10</b>	<b>M</b>	<b>/</b>	<b>AM</b>	<b>E</b>	<b>0</b>	<b>E</b>	<b>-</b>	<b>EC</b>	<b>SF</b>
-----------	------------	-----------	-------------	------------	----------	----------	-----------	----------	----------	----------	----------	-----------	-----------

<b>3E</b>	SERIES
<b>020</b>	SIZE 020 = 20 032 = 32
<b>BS</b>	TRANSMISSION BS = recirculating ball screw
<b>0100</b>	STROKE See table of mechanical characteristics
<b>P10</b>	SCREW PITCH P03 = 3 mm P10 = 10 mm
<b>M</b>	CONSTRUCTION M = male F = female
	EXTENDED ROD (___) = rod extended with ___ mm
<b>AM</b>	MOTOR CONNECTION AM = Kit Mod. AM PM = Kit Mod. PM
<b>E</b>	MOTOR A = MTS 17 B = MTS 23 C = MTS 24 E = DRVI-23ST (for size 32 only) F = DRVI-24ST (for size 32 only) G = DRVI-24EC (for size 32 only)
<b>0</b>	BRAKE 0 = without brake B = with brake
<b>E</b>	ENCODER VARIANTS 0 = without encoder (for motor A, B, C only) E = with encoder (for size 32 only)
<b>EC</b>	TYPE OF COMMUNICATION (for motor E, F, G only) PN = Profinet CO = CanOpen EC = Ethercat EI = Ethernet IP
<b>SF</b>	ADDITIONAL FUNCTIONS (for motor E, F, G only) = No additional function SF = STO (not certified)

## Configuration of cylinder with in line motor AM

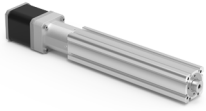

COMPACT ELECTROMECHANICAL CYLINDERS SERIES 3E

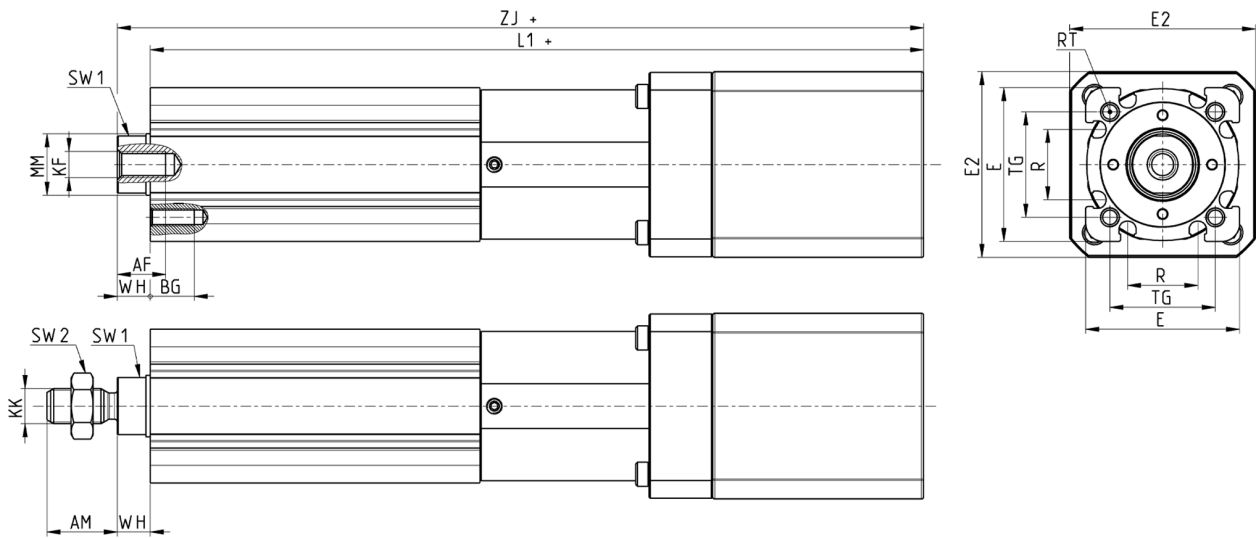

Mod.	Size	Motor	AM	AF	BG	E	E2	KF	KK	L1+	øMM	R	RT	SW1	SW2	TG	WH	ZJ+	weight stroke 0 [g]	weight stroke [kg/m]
.../AMA00	20	MTS-17-18-050-0-0-S-C	16	11	10	35	42,5	M6	M8x1,25	176	14	16	M4	13	13	24	7,5	184	800	2,57
.../AMAB0	20	MTS-17-18-050-0-F-S-C	16	11	10	35	42,5	M6	M8x1,25	206	14	16	M4	13	13	24	7,5	214	910	2,57
.../AMB00	32	MTS-23-18-060-0-0-S-C	19	13	10	42	56,4	M8	M10x1,25	163	14	19	M5	13	17	32,5	7,5	171	1000	3,64
.../AMBOE	32	MTS-23-18-060-0-0-E-C	19	13	10	42	73,5	M8	M10x1,25	189	14	19	M5	13	17	32,5	7,5	196	1100	3,64
.../AMBBE	32	MTS-23-18-060-0-F-E-C	19	13	10	42	73,5	M8	M10x1,25	230	14	19	M5	13	17	32,5	7,5	237	1200	3,64
.../AMC00	32	MTS-24-18-250-0-0-S-C	19	13	10	42	60	M8	M10x1,25	211	14	19	M5	13	17	32,5	7,5	218	1980	3,64
.../AMC0E	32	MTS-24-18-250-0-0-E-C	19	13	10	42	77,5	M8	M10x1,25	235	14	19	M5	13	17	32,5	7,5	243	2080	3,64
.../AMCBE	32	MTS-24-18-250-0-F-E-C	19	13	10	42	77,5	M8	M10x1,25	276	14	19	M5	13	17	32,5	7,5	284	2180	3,64

**FORCE-SPEED CURVES OF CYLINDER MOTOR IN LINE AM**

**With DRCS series drive**

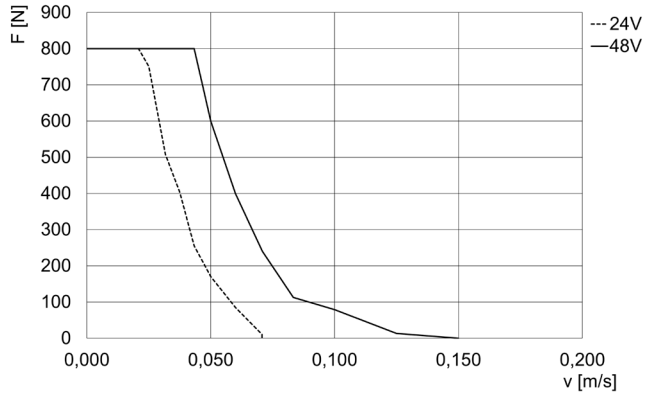

3E020BS...P03.../AMA... (MTS 17)

F = force [N]  
v = speed [m/s]

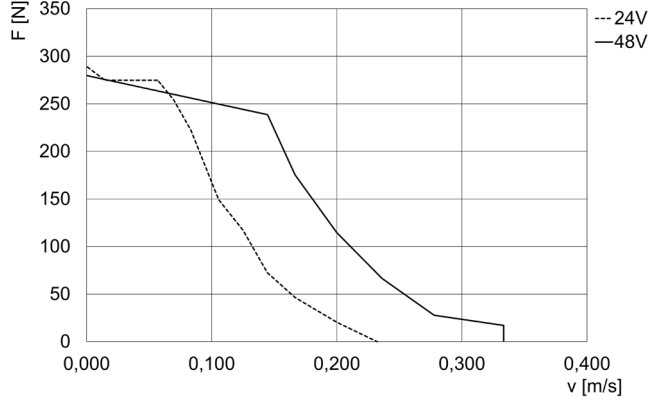

3E020BS...P10.../AMA... (MTS 17)

F = force [N]  
v = speed [m/s]

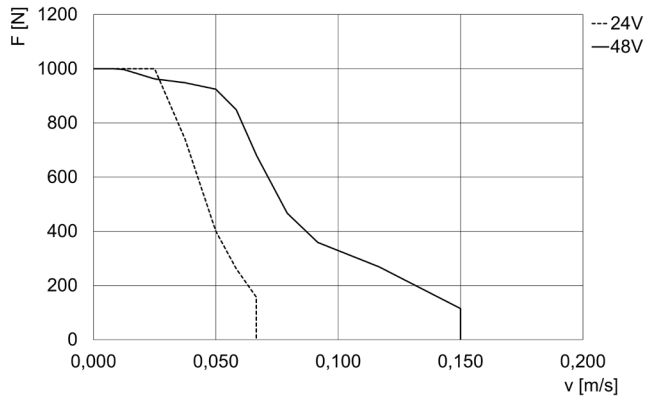

3E032BS...P03.../AMB... (MTS 23)

F = force [N]  
v = speed [m/s]

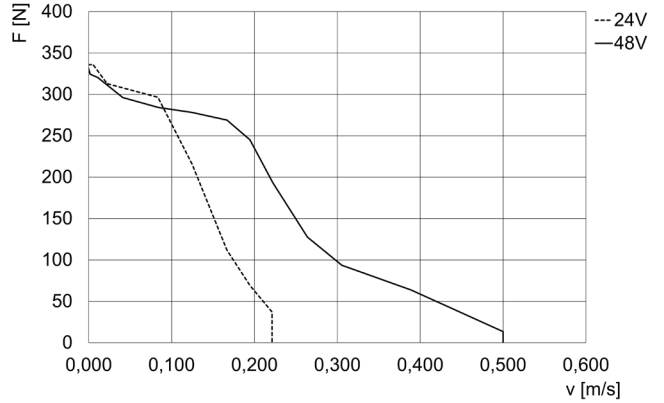

3E032BS...P10.../AMB... (MTS 23)

F = force [N]  
v = speed [m/s]

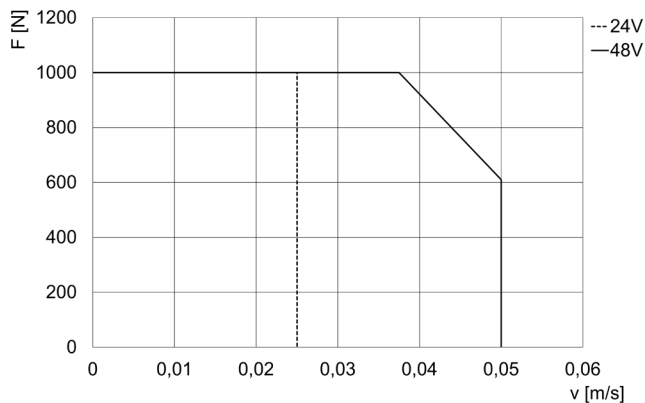

3E032BS...P03.../AMC... (MTS 24)

F = force [N]  
v = speed [m/s]

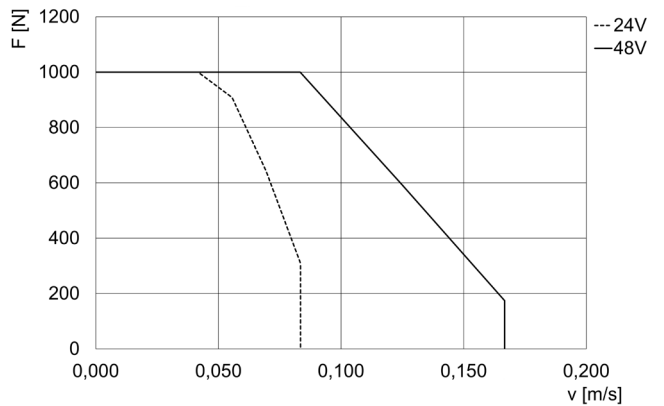

3E032BS...P10.../AMC... (MTS 24)

F = force [N]  
v = speed [m/s]

## Configuration of cylinder with in line motor AM + DRVI

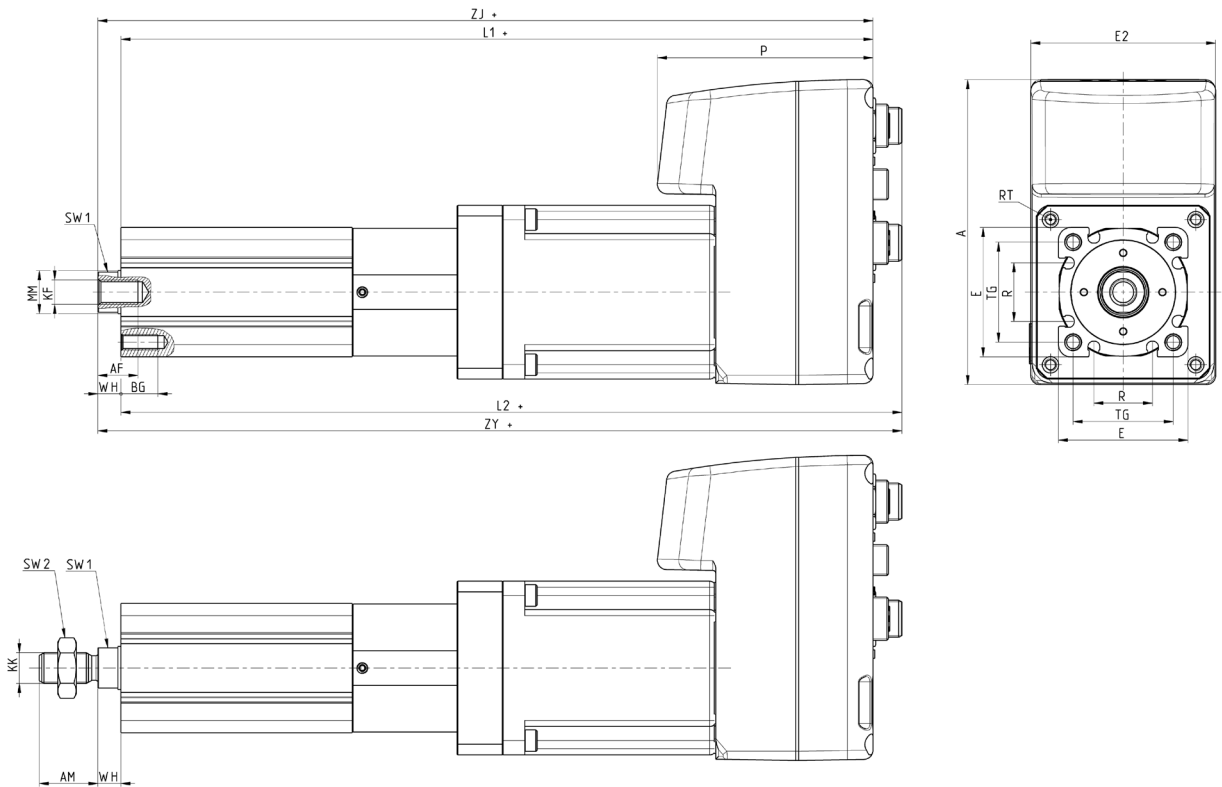

COMPACT ELECTROMECHANICAL CYLINDERS SERIES 3E

Mod.	Size	Motor	AM	AF	BG	A	E	E2	KF	KK	L1+	MM	R	P	RT	SW1	SW2	TG	WH	Z1+	L2+	ZY+	weight stroke 0 [g]	weight stroke [kg/m]
.../AME0-...	32	DRVI-23ST	19	13	10	99	42	60	M8	M10x1,25	249	14	19	70	M5	13	17	32,5	7,5	256,5	259	266	1660	3,64
.../AMEB-...	32	DRVI-23ST	19	13	10	99	42	60	M8	M10x1,25	289	14	19	70	M5	13	17	32,5	7,5	296,5	299	306	2390	3,64
.../AMF0-...	32	DRVI-24ST	19	13	10	99	42	60	M8	M10x1,25	275	14	19	70	M5	13	17	32,5	7,5	282,5	285	292	2240	3,64
.../AMFB-...	32	DRVI-24ST	19	13	10	99	42	60	M8	M10x1,25	315	14	19	70	M5	13	17	32,5	7,5	322,5	325	332	2970	3,64
.../AMG0-...	32	DRVI-24EC	19	13	10	99	42	60	M8	M10x1,25	254	14	19	70	M5	13	17	32,5	7,5	261,5	264	271	1700	3,64
.../AMGB-...	32	DRVI-24EC	19	13	10	99	42	60	M8	M10x1,25	294	14	19	70	M5	13	17	32,5	7,5	301,5	304	311	2430	3,64

**FORCE-SPEED CURVES MOTOR CYLINDER IN LINE AM + DRVI**

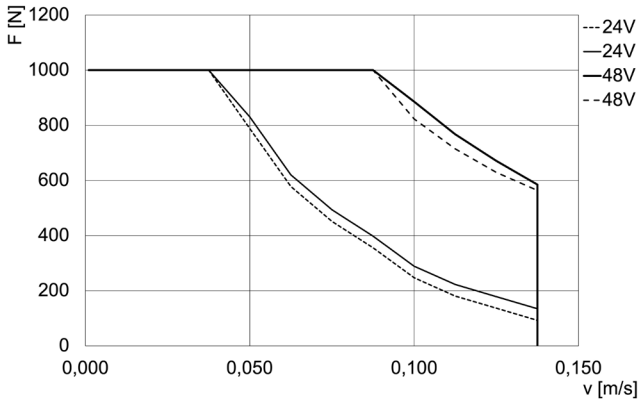

3E032BS...P03.../AME (DRVI-23ST)  
F = force [N]  
v = speed [m/s]  
Continuous lines = peak force of the actuator  
Dashed lines = nominal force of the actuator

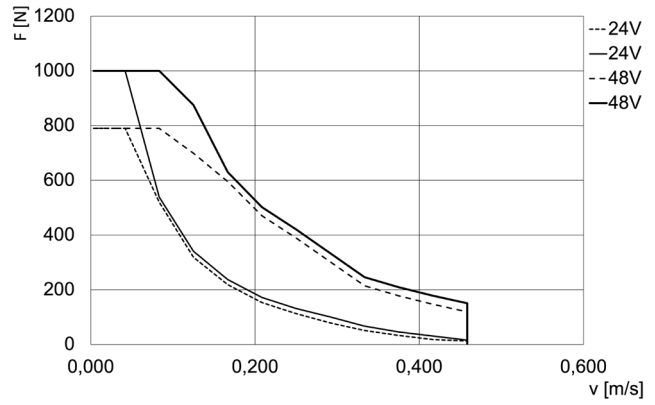

3E032BS...P10.../AME (DRVI-23ST)  
F = force [N]  
v = speed [m/s]  
Continuous lines = peak force of the actuator  
Dashed lines = nominal force of the actuator

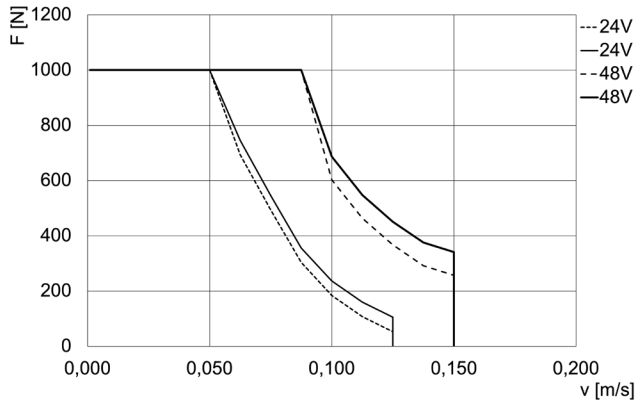

3E032BS...P03.../AMF (DRVI-24ST)  
F = force [N]  
v = speed [m/s]  
Continuous lines = peak force of the actuator  
Dashed lines = nominal force of the actuator

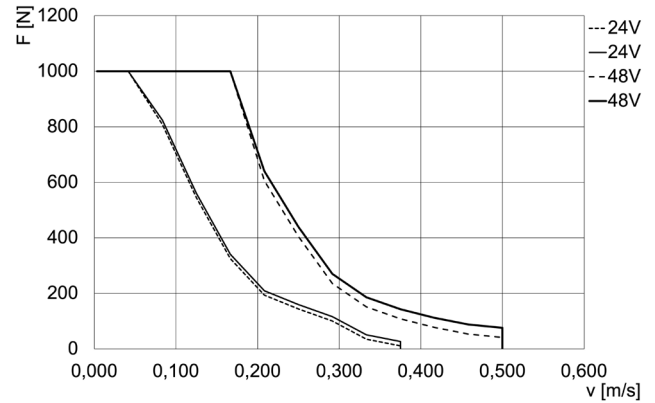

3E032BS...P10.../AMF (DRVI-24ST)  
F = force [N]  
v = speed [m/s]  
Continuous lines = peak force of the actuator  
Dashed lines = nominal force of the actuator

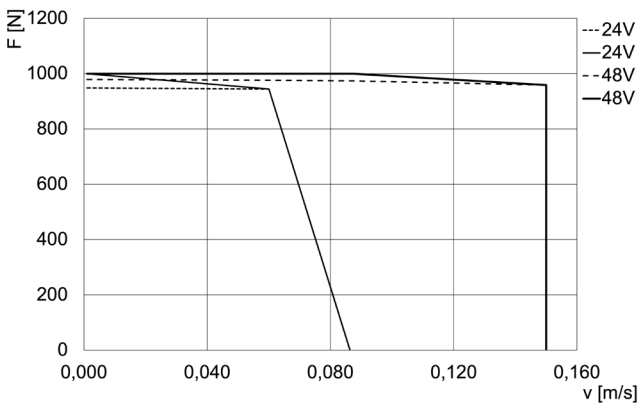

3E032BS...P03.../AMG (DRVI-24EC)  
F = force [N]  
v = speed [m/s]  
Continuous lines = peak force of the actuator  
Dashed lines = nominal force of the actuator

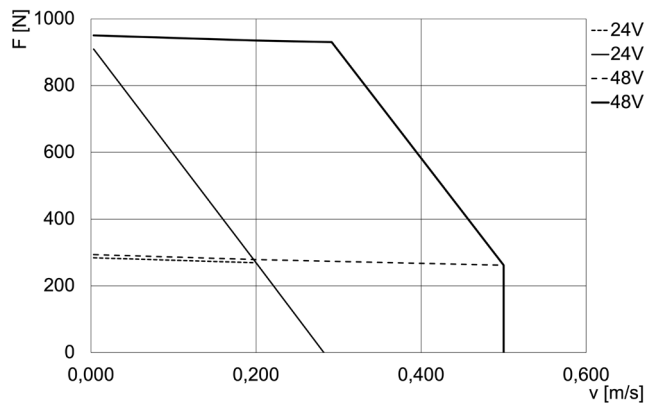

3E032BS...P10.../AMG (DRVI-24EC)  
F = force [N]  
v = speed [m/s]  
Continuous lines = peak force of the actuator  
Dashed lines = nominal force of the actuator



## Configuration of cylinder with parallel motor PM

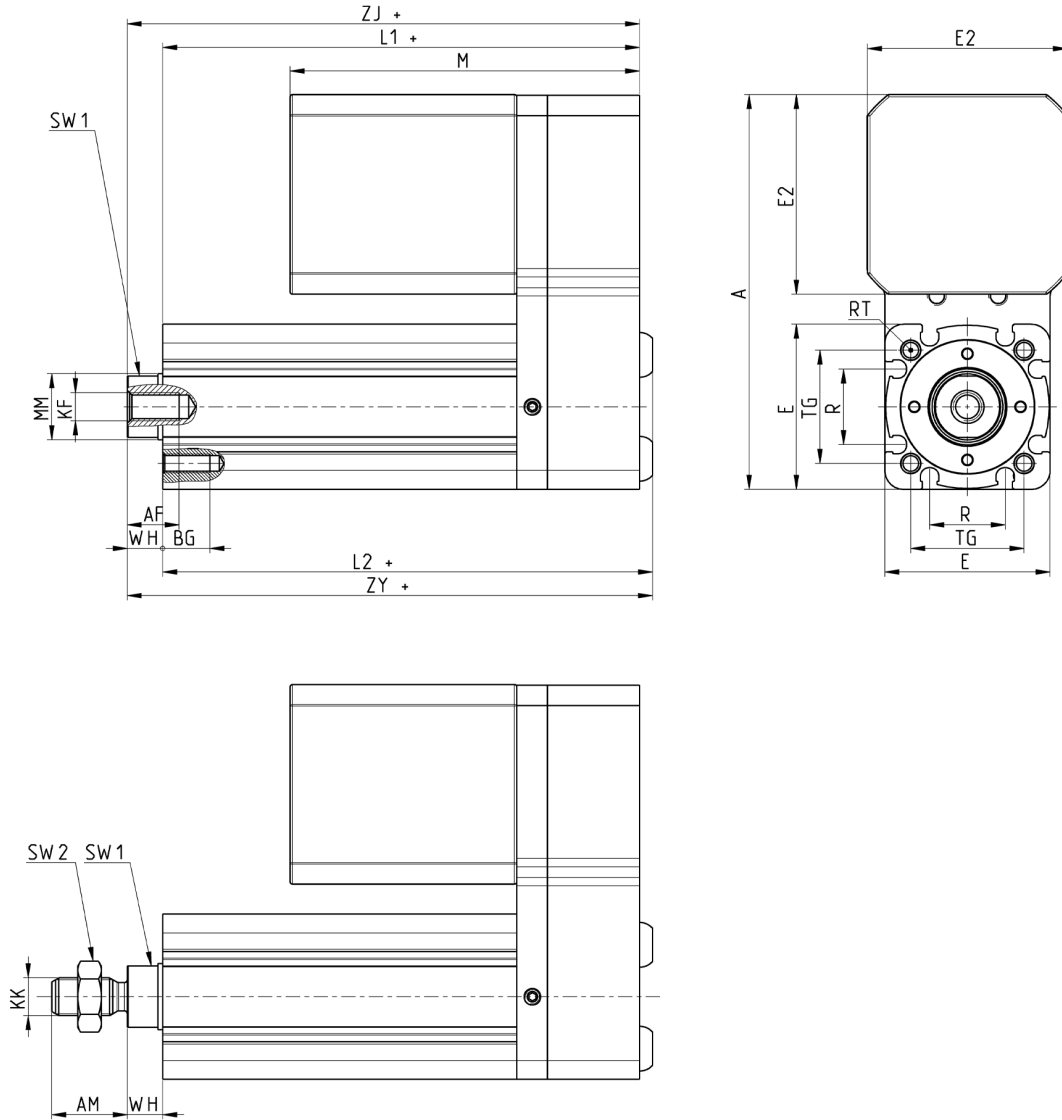
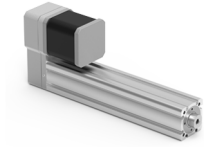

Mod.	Size	Motor	AM	AF	BG	E	E2	KF	M	A	KK	L1+	L2+	øMM	R	RT	SW1	SW2	TG	WH	ZI+	ZY+	minimum stroke suggested <sup>(A)</sup>	weight stroke 0 [g]	weight stroke [kg/m]
.../PMA00	20	MTS-17-18-050-0-0-S-C	16	11	10	35	42,5	M6	74	83,5	M8x1,25	101	104	14	16	M4	13	13	24	7,5	109	112	10	890	2,57
.../PMAB0	20	MTS-17-18-050-0-F-S-C	16	11	10	35	42,5	M6	104	83,5	M8x1,25	101	104	14	16	M4	13	13	24	7,5	109	112	10	1000	2,57
.../PMB00	32	MTS-23-18-060-0-0-S-C	19	13	10	42	56,4	M8	67	116,5	M10x1,25	103	106	14	19	M5	13	17	32,5	7,5	111	114	10	1240	3,64
.../PMB0E	32	MTS-23-18-060-0-0-E-C	19	13	10	42	56,4	M8	92,5	134	M10x1,25	103	106	14	19	M5	13	17	32,5	7,5	111	114	10	1340	3,64
.../PMBBE	32	MTS-23-18-060-0-F-E-C	19	13	10	42	56,4	M8	133,5	134	M10x1,25	103	106	14	19	M5	13	17	32,5	7,5	111	114	40	1440	3,64
.../PMC00	32	MTS-24-18-250-0-0-S-C	19	13	10	42	60	M8	114,5	118,5	M10x1,25	103	106	14	19	M5	13	17	32,5	7,5	111	114	20	2200	3,64
.../PMCOE	32	MTS-24-18-250-0-0-E-C	19	13	10	42	60	M8	139	136	M10x1,25	103	106	14	19	M5	13	17	32,5	7,5	111	114	45	2320	3,64
.../PMCB E	32	MTS-24-18-250-0-F-E-C	19	13	10	42	60	M8	180	136	M10x1,25	103	106	14	19	M5	13	17	32,5	7,5	111	114	85	2420	3,64

<sup>(A)</sup> Minimum stroke for L1 to be greater than M, see "mechanical characteristics" for minimum cylinder stroke.

**FORCE-SPEED CURVES MOTOR CYLINDER IN PARALLEL PM**

**With DRCS series drive**

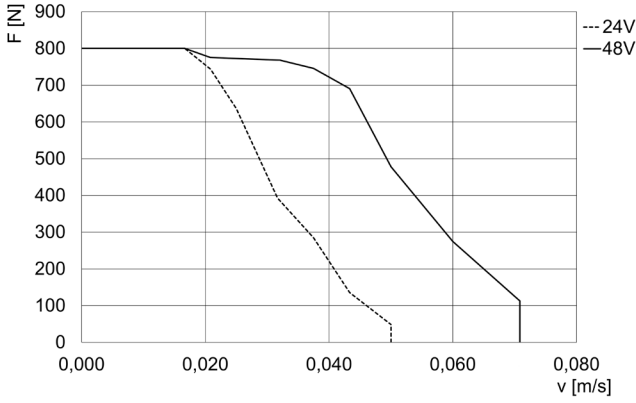

3E020BS...P03.../PMA... (MTS 17)

F = force [N]  
v = speed [m/s]

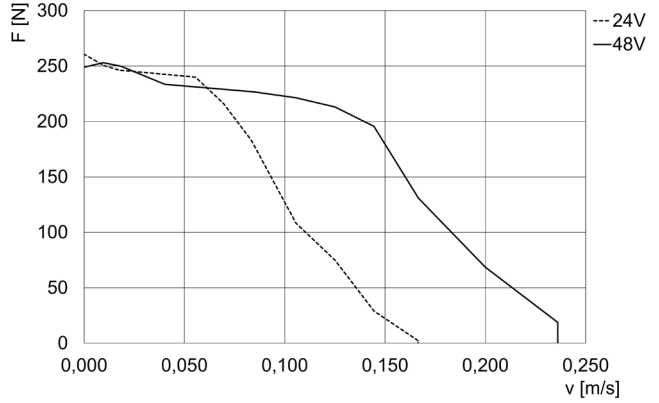

3E020BS...P10.../PMA... (MTS 17)

F = force [N]  
v = speed [m/s]

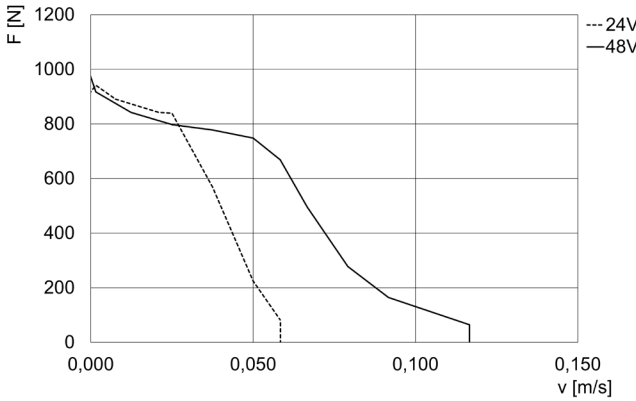

3E032BS...P03.../PMB... (MTS 23)

F = force [N]  
v = speed [m/s]

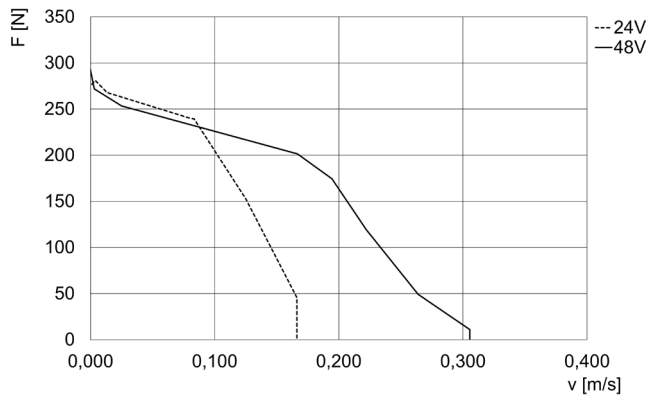

3E032BS...P10.../PMB... (MTS 23)

F = force [N]  
v = speed [m/s]

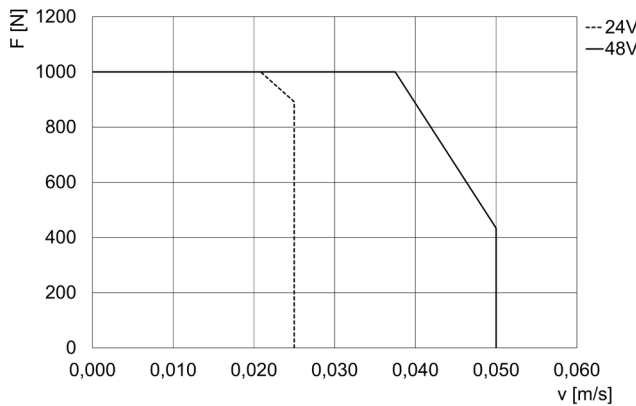

3E032BS...P03.../PMC... (MTS 24)

F = force [N]  
v = speed [m/s]

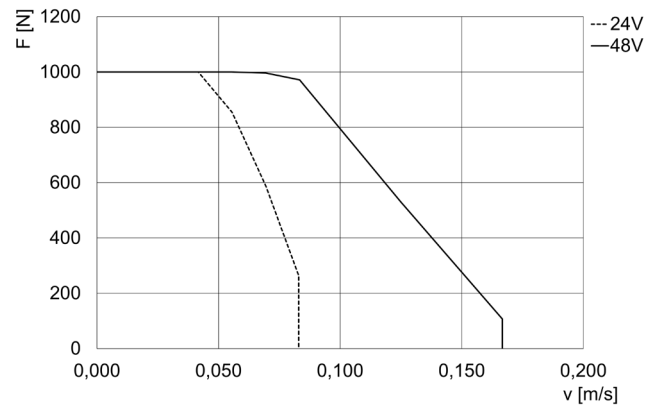

3E032BS...P10.../PMC... (MTS 24)

F = force [N]  
v = speed [m/s]

## Configuration of cylinder with in parallel motor PM + DRVI

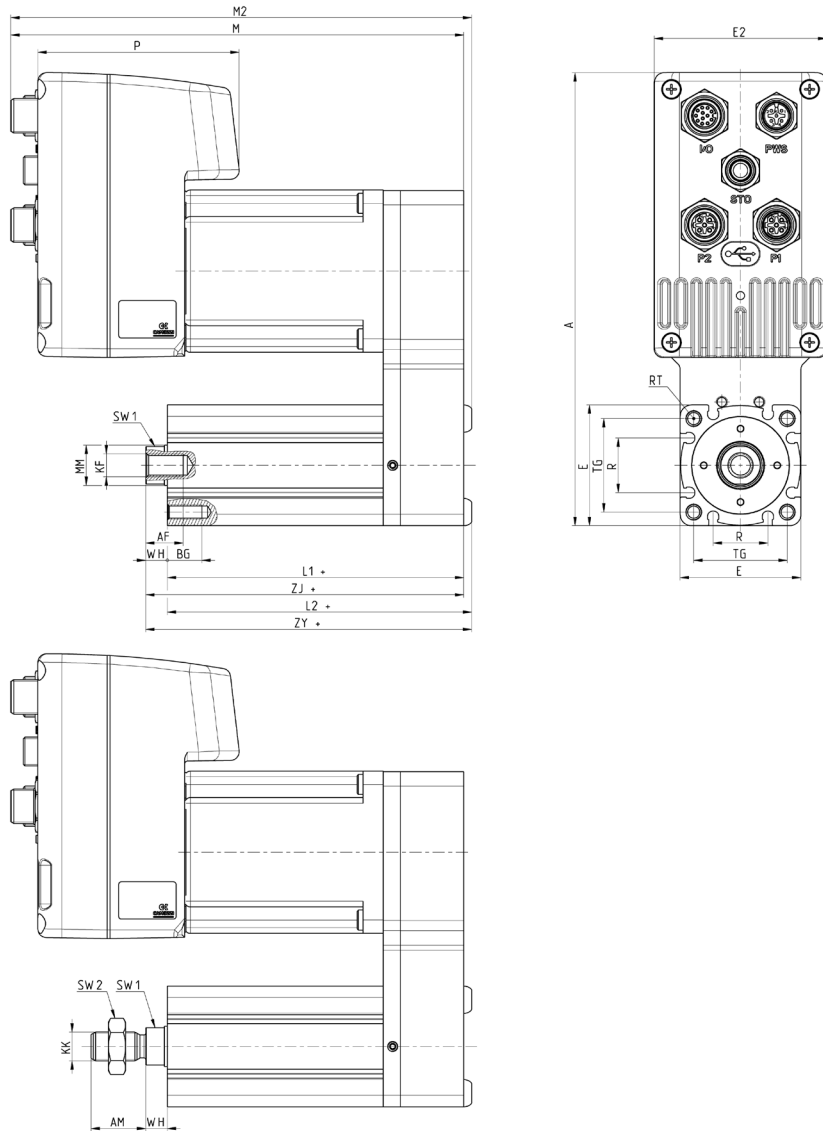

COMPACT ELECTROMECHANICAL CYLINDERS SERIES 3E

Mod.	Size	Motor	AM	AF	BG	E	E2	KF	M	P	A	KK	L1+	L2+	MM	R	RT	SW1	SW2	TG	WH	ZJ+	ZY+	minimum recommended stroke <sup>(A)</sup>	weight stroke 0 [g]	weight stroke [kg/m]
.../AME0-...	32	DRVI-23ST	19	13	10	42	60	M8	153	70	157,5	M10x1,25	103	106	14	19	M5	13	17	32,5	7,5	111	113,5	60	1900	3,64
.../AMEB-...	32	DRVI-23ST	19	13	10	42	60	M8	193	70	157,5	M10x1,25	103	106	14	19	M5	13	17	32,5	7,5	111	113,5	100	2630	3,64
.../AMF0-...	32	DRVI-24ST	19	13	10	42	60	M8	179	70	157,5	M10x1,25	103	106	14	19	M5	13	17	32,5	7,5	111	113,5	80	2480	3,64
.../AMFB-...	32	DRVI-24ST	19	13	10	42	60	M8	219	70	157,5	M10x1,25	103	106	14	19	M5	13	17	32,5	7,5	111	113,5	120	3210	3,64
.../AMG0-...	32	DRVI-24EC	19	13	10	42	60	M8	158	70	157,5	M10x1,25	103	106	14	19	M5	13	17	32,5	7,5	111	113,5	60	1940	3,64
.../AMGB-...	32	DRVI-24EC	19	13	10	42	60	M8	198	70	157,5	M10x1,25	103	106	14	19	M5	13	17	32,5	7,5	111	113,5	100	2670	3,64

<sup>(A)</sup> Minimum stroke for L1 to be greater than M, see "mechanical characteristics" for minimum cylinder stroke.

**FORCE-SPEED CURVES MOTOR CYLINDER IN PARALLEL PM + DRVI**

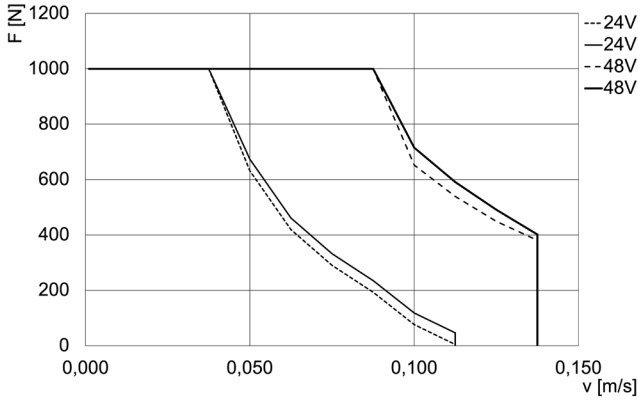

3E032BS...P03.../PME (DRVI-23ST)  
F = force [N]  
v = speed [m/s]  
Continuous lines = peak force of the actuator  
Dashed lines = nominal force of the actuator

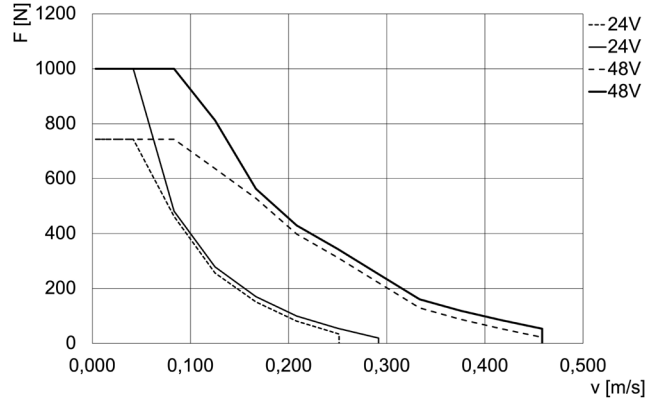

3E032BS...P10.../PME (DRVI-23ST)  
F = force [N]  
v = speed [m/s]  
Continuous lines = peak force of the actuator  
Dashed lines = nominal force of the actuator

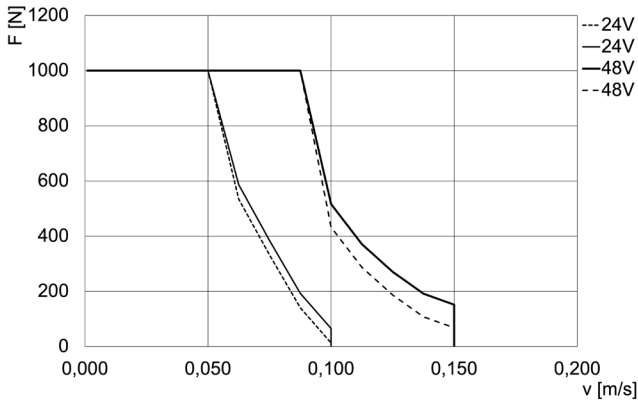

3E032BS...P03.../PMF (DRVI-24ST)  
F = force [N]  
v = speed [m/s]  
Continuous lines = peak force of the actuator  
Dashed lines = nominal force of the actuator

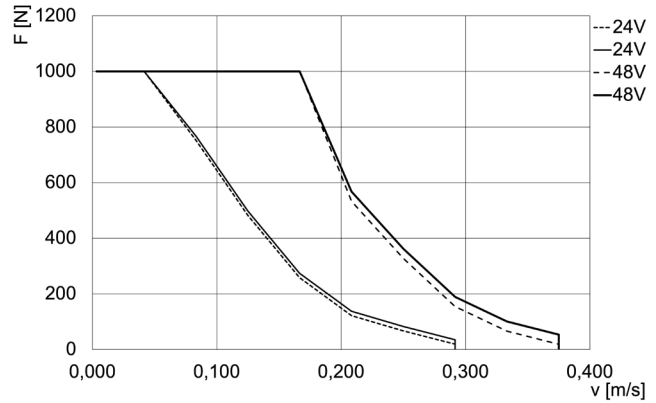

3E032BS...P10.../PMF (DRVI-24ST)  
F = force [N]  
v = speed [m/s]  
Continuous lines = peak force of the actuator  
Dashed lines = nominal force of the actuator

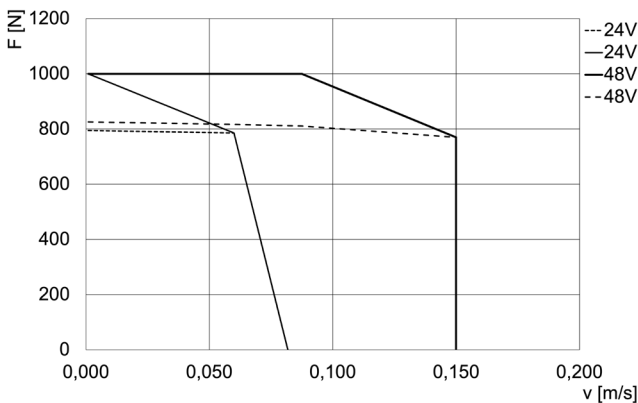

3E032BS...P03.../PMG (DRVI-24EC)  
F = force [N]  
v = speed [m/s]  
Continuous lines = peak force of the actuator  
Dashed lines = nominal force of the actuator

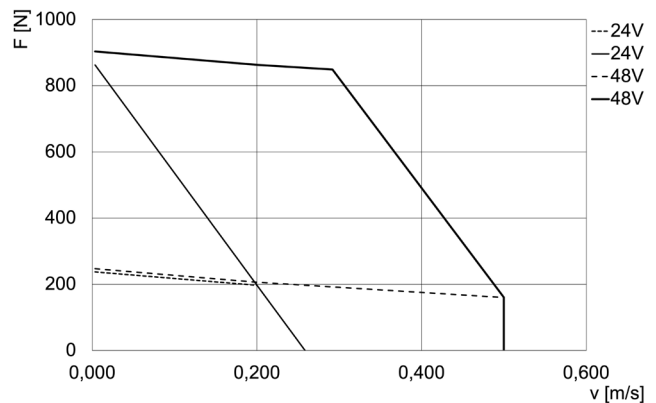

3E032BS...P10.../PMG (DRVI-24EC)  
F = force [N]  
v = speed [m/s]  
Continuous lines = peak force of the actuator  
Dashed lines = nominal force of the actuator